



AESV / AESU / AESV-LA SERIES **SQUIRREL CAGE INDUCTION MOTOR**

AESV1S / AESU1S / AESV1S-LA (IE1) STANDARD EFFICIENCY

AESV2S / AESU2S / AESV2S-LA (IE2) HIGH EFFICIENCY

AESV3S / AESU3S / AESV3S-LA (IE3) PREMIUM EFFICIENCY

BACKGROUND

ABOUT TECO

TECO Singapore provides a total solution of motors and drives ever since it was established in 1972.

TECO Westinghouse Motor Company comprises the experience of Westinghouse, a leader in the motor industry since 1888 and TECO, a multinational conglomerate with over 50 years of motor experience. TECO Singapore itself was established in 1972 and has also set-up subsidiaries in Thailand, Malaysia, Indonesia, Vietnam and India.

By realizing the potential for precision products, especially in electronic and electrical equipment, TECO embarked a foothold in Singapore and becomes a hub for manufacturing and distribution of Electric Motors for the entire South-East Asia since 1972. TECO Singapore has established overseas manufacturing facilities and offices in Thailand, Malaysia, Indonesia, Vietnam and India.

Today, TECO is the one of the top 5 motor manufacturers in the world. Our motors are widely deployed in the industrial sectors and government projects including Singapore Mass Rapid Transit (SMRT), Land Transport Authority (LTA), Public Utilities Board (PUB), Housing Development Board (HDB) and Jurong Town Council (JTC) and Changi Airport.

INTRODUCTION TO IEC 60034-30-1

Electric motor application in the industry consumes between 30% and 40% of the generated electrical energy worldwide. Improving efficiency of the complete drive system is therefore a major concern in the energy-efficiency efforts.

Many different energy efficiency standards for cage induction motors from different countries were already in use (NEMA, EPACT, CSA, CEMEP, COPANT, AS/NZS, JIS, GB and others) before IEC came up with an efficiency standard. It became increasingly difficult for manufacturers to design motors for a global market and for customers to understand differences and similarities of standards in different countries, therefore IEC 60034-30-1 was developed for global standards for easy reference.

IEC 60034-30-1: Efficiency classes of single-Speed, Three Phase, Cage-induction motor (IE-code)

As part of a concerted effort worldwide to reduce energy consumption, CO2 emissions and the impact of industrial operations on the environment, TECO is committed to produce International Energy-Efficiency Class (IE) motors in order to reduce the energy consumed and in turn reduce greenhouse gas emissions. TECO's V-series are designed, manufactured and tested to meet latest European and International standard. The New V Series, which comprise of full range of Efficiency Classes IE1, IE2 & IE3 Motors.

WHAT DOES THIS STANDARD COVERS?

It specifies efficiency classes for single-speed, three-phase, 50Hz and 60 Hz, cage-induction motors that have:

- Rated Voltage above 50V up to 1000V;
- Rated Output Power between 0.12kW and 1000kW;
- Either 2, 4, 6 or 8 pole;
- Rated either duty type S1 (continuous duty) or S3 (intermittent periodic duty) with a rated cycle duration factor of 80% or higher;
- Capable of operating direct on-line;
- Rated for operating conditions in accordance with IEC 60034-1, clause 6.

INTRODUCTION TO SINGAPORE MINIMUM EFFICIENCY PERFORMANCE STANDARD (MEPS)

In September 2016, Singapore ratified the Paris Agreement and formalized its pledge to reduce its emissions intensity by 36% below 2005 levels by 2030 and stabilize its emissions with the aim of peaking around 2030.

RATIONALE & BENEFIT OF MEPS FOR MOTORS

- ✓ Transform the market towards more efficient motors
- ✓ Reduce total life-cycle cost for end-users
- ✓ Reduce energy use and greenhouse gas emissions

SCOPE OF MEPS IN SINGAPORE

Single Speed 3-Phase Induction Motors:

- 50Hz
- 2, 4 and 6 Pole
- Rated Output Power from 0.75 kW to 375 kW
- Rated Voltage up to 1,000 V
- Rated on the basis of continuous duty operation

EXCLUSIONS OF MEPS

- a) Motors specifically designed to operate
 - Where ambient air temperature exceed 60°C
 - In maximum operating temperature above 400°C
 - Where ambient air temperatures are less than -30°C for any motor or less than 0°C for a motor with water cooling
 - In potentially explosive environment
- b) Motors that operate wholly immersed in a liquid
- c) Multi-speed motors, brake motors and torque motors
- d) Motors that are completely integrated into a product where the motors' energy performance cannot be tested independently from the product (e.g. chiller compressor)
- e) Motors supplied exclusively to a 3rd party who will incorporate the motors into equipment that will be exported to other countries

ELECTRICAL DESIGN

Type: Squirrel Cage Induction Motor
Ratings: 0.55 kW ~ 375 kW

Duty Rating

All motors have a maximum continuous duty rating of S1 under rated load. For duty cycles other than S1 please refer to TECO.

Supply Voltage

Stock motors are designed for operation as below:
2.2kW and below : 220~240V/ 380~415V 3 phase /50Hz
3 kW and above : 380~415V 3 phase /50Hz

Insulation System

All motors are design with Class F insulation and Class B temperature rise at ambient temperature of 40° C. For any other insulation system other than standard Class F insulation or Class B temperature rise at higher ambient temperature than standard 40° C, please refer to TECO.

Inverter Duty

All motors are design to be suitable for Inverter use, comply with IEC 60034-17 : 2006. For intensive use of Inverter duty operations complying to IEC60034-25, please refer to TECO.

Standards

IEC 60034-1 Rotating electrical machines - Part 1: Rating and performance.

IEC 60034-2-1 Rotating electrical machines - Part 2-1: Standard methods for determining losses and efficiency from tests

IEC 60034-5 Rotating electrical machines - Part 5: Degrees of protection provided by the integral design of rotating electrical machines (IP code) - classification.

IEC 60034-6 Rotating electrical machines - Part 6: Methods of cooling (IC code).

IEC 60034-7 Rotating electrical machines - Part 7: Classification of types of enclosures and mounting arrangements (IM code).

IEC 60034-8 Rotating electrical machines - Part 8: Terminal markings and direction of rotation.

IEC 60034-9 Rotating electrical machines - Part 9: Noise limits.

IEC 60034-11-1 Rotating electrical machines - Part 11-1: Thermal protection.

IEC 60034-12 Rotating electrical machines - Part 12: Starting performance of single-speed three-phase cage induction motors.

IEC 60034-14 Rotating electrical machines - Part 14: Mechanical vibration of certain machines - Limits of vibration.

IEC 60034-17 : 2006 Rotating electrical machines - Part 17: Cage induction motors when fed from converters - Application guide.

IEC 60034-30-1 Rotating electrical machines - Part 30:Efficiency classes for single-speed three-phase cage induction motors.

CONNECTION DIAGRAM

Direct-On-Line

For motor rating 2.2kW and below:
Low Voltage : 220~240V
High Voltage : 380~415V

For motor rating 3kW and above:
Low Voltage : 380~415V

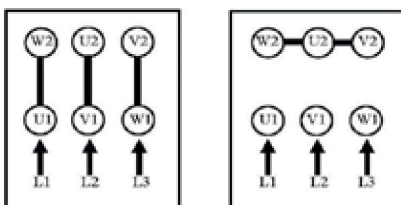

Star-Delta

Connect U1,V1,W1,U2,V2 & W2 to Star-Delta starter panel.

Power Supply Voltage (L1,L2,L3) to be connected to voltage indicated in Delta configuration column on the motor nameplate.

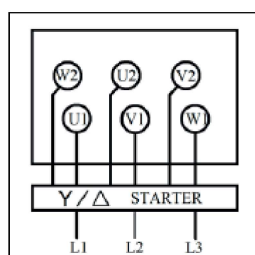

MECHANICAL DESIGN

Type: Squirrel Cage Induction Motor

Frame: 80M to 355C

Enclosure: Totally Enclosed Fan Cooled (TEFC), Totally Enclosed Air Over (TEAO)

Ingress Protection

Stock motors are design to meet Ingress Protection of IP55, other special requirement please refer to TECO.

Drive Method

Stock motors are design for both Direct Coupling and Belt Drive use from frame size 80M to 250M. However, for 2 Pole Motor design for both Direct Coupling and Belt Drive is from Frame size 80M to 200L only. For belt drive application for other frame size, please refer to TECO.

Bearings

High Quality Deep Groove Ball Sealed Bearings are use for our stock motor from frame size 80 to 225M and Vacuum De-Gassed High Quality Deep Groove Ball Open Bearings are use for stock motor from frame Size 250M to 355C. Any special bearings, please refer to TECO.

Lubrication

Both our sealed and open type bearing are grease lubricated.

Construction

Frame: High Grade Cast Iron

End Bracket: High Grade Cast Iron

External Fan: Polypropylene

Fan Cover: Pressed Steel

Shaft: Carbon Steel

Lead: 6 Leads

Iron Core: High Grade, Insulated, Cold Rolled,
Electro Magnetic Steel Plate

Terminal Box

Stock motor are fitted with pressed steel T-Box for Frame 80M to 180M and Cast Iron T-Box for Frame 200L to 355M. T-Box are designed for provision of rotation by 90° to every direction that enable cable entry from 4 directions.

Finishing

Stock motor are completed with Phenolic Rust Proof Base Plus Lacquer Surface Finished Painting as standard:

Gray Color (Munsell 7.5B 3.5/0.5) (IE 1)

Blue Color (Munsell 5PB 3/8) (IE 2)

Green Color (Munsell 7.5GY 4.5/3.5) (IE 3)

Any other colour finishing, please refer to TECO.

Lifting Device

All motor from Frame Size 90 and above comes with lifting lugs for lifting purposes.

Standards

IEC 60072-1 Dimensions and output series for rotating electrical machines - Part 1: Frame numbers 56 to 400 and flange numbers 55 to 1080.

SPECIAL ENHANCEMENT

The following enhancement are also available. Please refer to TECO.

- ✓ IP 56
- ✓ Class 'H' Insulation
- ✓ Inverter Duty Wire
- ✓ Special Paint Finishes
- ✓ Special Shaft Extensions
- ✓ Dual Speed
- ✓ Smoke Spill Duty
- ✓ Stainless Steel Hardware
- ✓ Conversion of sealed bearing to open bearing

OPTIONAL ACCESSORIES

Thermal Protection Accessories

- ✓ PTC Thermistors
- ✓ Resistance Temperature Detectors (RTD)
- ✓ Thermostat

Moisture Protection Accessories

- ✓ Space Heater

IE 1 PERFORMANCE DATA (2 POLE)

Motor Type: AESV1S / AESU1S / AESV1S-LA



OUTPUT		FULL LOAD rpm	FRAME No.	EFFICIENCY			POWER FACTOR			CURRENT				TORQUE			ROTOR GD ² kg-m ²	APPROX. WEIGHT kg	
kW	HP			FULL LOAD (%)	3/4 LOAD (%)	1/2 LOAD (%)	FULL LOAD (%)	3/4 LOAD (%)	1/2 LOAD (%)	FULL LOAD (A)			LRC (A)	FULL LOAD kg-m	LOCKED ROTOR %FLT	PULL-UP %FLT			BREAK-DOWN %FLT
										VOLTAGE									
								380	400	415	400V								
0.75	1	2800	80M	72.1	71.6	68.8	88.0	81.0	68.0	1.80	1.71	1.64	11	0.261	235	210	255	0.005	15.0
1.1	1.5	2810	80M	75.0	75.9	74.5	87.5	81.0	70.0	2.55	2.42	2.33	17	0.381	265	235	290	0.006	16.0
1.5	2	2850	90S	77.2	77.2	75.3	88.0	82.0	70.5	3.35	3.19	3.07	21	0.512	225	210	290	0.010	21.0
2.2	3	2855	90L	79.7	80.7	79.7	89.0	84.0	74.0	4.71	4.48	4.31	33	0.750	240	230	310	0.013	25.0
3	4	2890	100L	81.5	82.0	80.5	89.0	85.0	76.0	6.28	5.97	5.75	50	1.010	215	195	280	0.022	34.5
3.7	5	2880	112M	82.6	83.6	81.6	90.0	87.0	79.0	7.56	7.18	6.92	62	1.250	240	180	320	0.042	44.0
4	5.5	2910	112M	83.1	84.1	83.1	90.5	87.5	79.5	8.08	7.68	7.40	67	1.337	200	170	325	0.042	44.0
5.5	7.5	2900	132S	84.7	83.7	81.3	88.0	85.5	79.0	11.2	10.7	10.3	69	1.845	170	150	235	0.057	55.0
7.5	10	2895	132S	86.0	86.0	84.5	82.0	80.0	76.0	16.2	15.4	14.8	91	2.521	170	145	225	0.063	56.0
11	15	2945	160M	87.6	87.6	85.6	89.0	85.5	77.5	21.4	20.4	19.6	176	3.634	225	140	280	0.154	94.0
15	20	2940	160M	88.7	89.2	88.2	91.0	90.0	85.5	28.2	26.8	25.9	210	4.964	220	135	260	0.192	109
18.5	25	2940	160L	89.3	89.8	89.3	92.0	90.0	85.5	34.2	32.5	31.3	291	6.123	270	190	310	0.237	124
22	30	2945	180M	89.9	89.9	88.9	90.0	88.0	83.5	41.3	39.2	37.8	314	7.269	220	175	280	0.283	161
30	40	2955	200L	90.7	90.2	87.7	84.5	79.0	71.0	59.5	56.5	54.5	441	9.878	185	140	275	0.521	212
37	50	2955	200L	91.2	91.2	90.2	88.5	87.0	81.0	69.6	66.2	63.8	527	12.18	195	135	270	0.663	242
45	60	2955	225MA	91.7	91.2	89.7	91.5	90.0	86.0	81.5	77.4	74.6	600	14.82	150	130	260	1.074	275
55	75	2970	250MA	92.1	92.1	91.1	91.0	90.0	85.5	99.7	94.7	91.3	697	18.02	135	115	295	1.343	354
75	100	2970	280SA	92.7	92.7	91.4	87.0	85.0	80.0	141	134	129	1072	24.57	130	120	260	1.759	458
90	125	2965	280MA	93.0	92.8	91.9	87.0	84.0	76.5	169	161	155	1288	29.53	140	120	290	2.023	485
110	150	2965	315SA	93.5	93.5	92.8	89.0	87.0	81.1	201	191	184	1400	36.10	140	120	230	3.002	613
132	175	2970	315MA	93.7	93.7	93.0	89.5	88.5	83.5	239	227	219	1570	43.24	145	120	230	4.400	750
(160)	(215)	2970	315MA	94.0	94.0	93.2	91.5	90.5	86.0	283	269	259	2050	52.42	210	175	240	5.200	800
160	215	2970	315LA	94.0	94.0	93.2	91.5	90.5	86.0	283	269	259	2050	52.42	210	175	240	5.200	806
200	270	2970	315LA	94.0	94.0	93.4	92.0	91.0	87.5	351	334	322	2500	65.52	210	175	240	6.400	926
(220)	(300)	2970	315CA	94.4	94.0	92.8	90.5	89.0	83.5	391	372	358	2800	72.07	150	125	270	7.200	1380
220	300	2970	355MA	94.4	94.0	92.8	90.5	89.0	83.5	391	372	358	2800	72.07	150	125	270	7.200	1185
(250)	(335)	2972	315CA	94.6	94.1	93.0	92.0	91.0	87.5	436	415	400	3100	81.85	150	125	270	8.400	1500
250	335	2972	355MA	94.6	94.1	93.0	92.0	91.0	87.5	436	415	400	3100	81.85	150	125	270	8.400	1305
(315)	(420)	2975	315DA	94.8	94.4	93.5	92.5	91.5	88.0	546	518	500	3900	103.0	160	130	280	10.40	1720
315	420	2975	355LA	94.8	94.4	93.5	92.5	91.5	88.0	546	518	500	3900	103.0	160	130	280	10.40	1525
375	500	2980	355CA	94.8	94.8	93.7	92.0	90.5	86.5	653	621	598	4500	122.4	150	125	280	12.40	2340

Note:

1. The above are typical values based on test according to IEC 60034-2-1 :2007.(DY)
2. Tolerance according to IEC 60034-1.
3. Breakdown & Locked rotor torques are show as average expected voltages
4. Efficiency, power factor, speed and torque are the same for other voltages.
Current values vary inversely with voltage
5. Output in () is for Optional Frame size upon request
6. Frame size 315C, 315D, & 355C: only suitable for IM B3 and IM B35
7. Noise according to IEC 60034-9.
8. Data subject to change without prior notice.



IE 1 PERFORMANCE DATA (4 POLE)

Motor Type: AESV1S / AESU1S / AESV1S-LA

OUTPUT		FULL LOAD rpm	FRAME No.	EFFICIENCY			POWER FACTOR			CURRENT				TORQUE				ROTOR GD ² kg-m ²	APPROX. WEIGHT kg
kW	HP			FULL LOAD (%)	3/4 LOAD (%)	1/2 LOAD (%)	FULL LOAD (%)	3/4 LOAD (%)	1/2 LOAD (%)	FULL LOAD (A)			LRC (A) 400V	FULL LOAD kg-m	LOCKED ROTOR %FLT	PULL-UP %FLT	BREAK-DOWN %FLT		
										VOLTAGE									
					380	400	415												
0.55	0.75	1425	80M	70.0	68.9	62.1	73.0	62.5	50.0	1.65	1.57	1.51	9.0	0.376	220	200	265	0.007	15.0
0.75	1	1425	80M	72.1	71.6	68.3	77.0	66.0	52.5	2.05	1.95	1.88	12	0.512	240	215	275	0.009	16.0
1.1	1.5	1425	90S	75.0	75.0	68.1	79.0	68.5	55.5	2.82	2.68	2.58	17	0.751	220	165	235	0.014	18.0
1.5	2	1425	90L	77.2	77.2	74.2	81.0	72.5	59.0	3.64	3.46	3.34	23	1.024	230	175	240	0.017	20.0
2.2	3	1435	100L	79.7	79.7	77.2	79.5	71.0	57.0	5.28	5.01	4.83	39	1.492	210	185	300	0.033	30.0
3	4	1445	100L	81.5	80.9	77.5	85.0	76.0	63.0	6.58	6.25	6.02	52	2.020	250	180	300	0.046	32.5
3.7	5	1445	112M	82.6	82.6	80.6	82.0	74.5	64.0	8.30	7.88	7.60	62	2.491	220	180	290	0.059	38.0
4	5.5	1445	112M	83.1	83.6	81.7	82.0	76.0	64.0	8.92	8.47	8.17	60	2.693	190	180	260	0.065	38.0
5.5	7.5	1465	132S	84.7	84.7	83.2	82.5	75.5	63.5	12.0	11.4	11.0	86	3.653	235	190	315	0.103	53.5
7.5	10	1460	132M	86.0	86.5	85.0	86.0	81.5	71.5	15.4	14.6	14.1	109	4.998	215	175	295	0.133	67.0
11	15	1465	160M	87.6	88.1	87.1	86.5	82.5	74.5	22.1	21.0	20.2	155	7.306	200	150	255	0.271	94.0
15	20	1465	160L	88.7	88.7	87.2	86.0	80.5	71.0	29.9	28.4	27.4	217	9.962	215	155	265	0.396	119
18.5	25	1475	180M	89.3	89.3	88.8	86.0	83.5	76.5	36.6	34.8	33.5	220	12.20	165	125	220	0.611	161
22	30	1475	180L	89.9	89.9	88.9	84.0	80.5	72.5	44.3	42.0	40.5	299	14.51	195	150	230	0.712	176
30	40	1475	200L	90.7	91.2	90.7	86.5	83.5	76.5	58.1	55.2	53.2	444	19.79	240	185	275	1.220	227
37	50	1480	225SC	91.2	90.7	89.7	85.0	81.5	74.5	72.5	68.9	66.4	489	24.33	190	160	245	1.649	277
45	60	1475	225MC	91.7	92.2	91.2	85.5	83.0	76.5	87.2	82.8	79.8	523	29.68	175	145	220	1.731	290
55	75	1485	250MC	92.1	92.1	91.1	87.0	85.0	79.5	104	99.1	95.5	714	36.04	220	110	230	2.755	399
75	100	1480	280SB	92.7	92.7	92.2	84.5	81.0	73.5	145	138	133	948	49.31	175	165	275	4.224	508
90	125	1480	280MB	93.0	93.2	92.5	85.5	82.5	72.5	172	163	157	1164	59.17	175	165	270	4.943	557
110	150	1480	315SB	93.5	93.5	92.9	86.5	83.8	76.2	207	196	189	1350	72.32	190	155	250	6.635	671
132	175	1480	315MB	93.7	93.7	93.2	86.5	83.0	74.5	247	235	227	1570	86.78	200	165	250	8.400	750
(160)	(215)	1482	315MB	94.0	94.0	93.4	87.5	84.5	77.0	296	281	271	2000	105.0	200	165	250	10.00	810
160	215	1482	315LB	94.0	94.0	93.4	87.5	84.5	77.0	296	281	271	2000	105.0	200	165	250	10.00	816
200	270	1482	315LB	94.0	94.1	93.6	88.5	86.0	79.0	365	347	334	2500	131.3	210	175	250	13.20	986
(220)	(300)	1484	315CB	94.5	94.5	93.7	89.5	88.0	82.5	395	375	362	2840	144.2	200	165	250	19.20	1420
220	300	1484	355MB	94.5	94.5	93.7	89.5	88.0	82.5	395	375	362	2840	144.2	200	165	250	19.20	1225
(250)	(335)	1485	315CB	94.6	94.5	93.8	89.5	87.5	82.0	449	426	411	3150	163.8	200	165	260	21.20	1500
250	335	1485	355MB	94.6	94.5	93.8	89.5	87.5	82.0	449	426	411	3150	163.8	200	165	260	21.20	1305
(315)	(420)	1485	315DB	94.9	94.9	94.4	90.0	88.0	82.5	560	532	513	4100	206.4	200	165	260	26.40	1780
315	420	1485	355LB	94.9	94.9	94.4	90.0	88.0	82.5	560	532	513	4100	206.4	200	165	260	26.40	1585
375	500	1486	355CB	94.9	94.9	94.4	89.5	88.0	82.0	671	637	614	4500	245.5	200	165	270	34.80	2340

Note:

1. The above are typical values based on test according to IEC 60034-2-1 :2007.(DY)
2. Tolerance according to IEC 60034-1.
3. Breakdown & Locked rotor torques are show as average expected voltages
4. Efficiency, power factor, speed and torque are the same for other voltages.
Current values vary inversely with voltage
5. Output in () is for Optional Frame size upon request
6. Frame size 315C, 315D, & 355C: only suitable for IM B3 and IM B35
7. Noise according to IEC 60034-9.
8. Data subject to change without prior notice.

IE 1 PERFORMANCE DATA (6 POLE)

Motor Type: AESV1S / AESU1S / AESV1S-LA



OUTPUT		FULL LOAD rpm	FRAME No.	EFFICIENCY			POWER FACTOR			CURRENT				TORQUE			ROTOR GD ² kg-m ²	APPROX. WEIGHT kg	
kW	HP			FULL LOAD (%)	3/4 LOAD (%)	1/2 LOAD (%)	FULL LOAD (%)	3/4 LOAD (%)	1/2 LOAD (%)	FULL LOAD (A)			LRC (A)	FULL LOAD kg-m	LOCKED ROTOR %FLT	PULL-UP %FLT			BREAK-DOWN %FLT
										VOLTAGE									
								380	400	415	400V								
0.55	0.75	915	80M	67.5	67.0	62.0	72.0	60.5	48.0	1.72	1.63	1.57	8.0	0.585	220	210	225	0.012	18.0
0.7		935	90S	70.0	67.2	62.9	71.0	60.5	48.0	2.29	2.18	2.10	11	0.780	190	175	285	0.017	22.5
1.1	1.5	935	90L	72.9	71.0	66.1	68.5	57.0	44.5	3.35	3.18	3.06	17	1.145	220	205	260	0.023	25.0
1.5	2	935	100L	75.2	75.2	69.8	75.0	65.0	52.0	4.04	3.84	3.70	21	1.561	200	170	235	0.035	29.0
2.2	3	950	112M	77.7	77.7	74.8	73.5	63.0	50.0	5.85	5.56	5.36	34	2.253	205	195	270	0.058	39.0
3	4	965	132S	79.7	79.7	77.3	72.5	63.5	50.0	7.89	7.49	7.22	45	3.025	195	185	270	0.097	54.0
3.7	5	960	132M	80.9	80.9	75.9	75.5	65.5	53.5	9.20	8.74	8.43	61	3.750	180	160	230	0.114	58.0
4	5.5	960	132M	81.4	81.9	80.4	77.5	69.5	56.5	9.63	9.15	8.82	59	4.054	190	175	275	0.131	58.0
5.5	7.5	965	132M	83.1	82.6	81.1	72.0	63.5	50.0	14.0	13.3	12.8	92	5.546	210	160	280	0.171	70.0
7.5	10	960	160M	84.7	83.7	81.3	81.5	76.5	66.0	16.5	15.7	15.1	94	7.602	210	185	255	0.363	99.0
11	15	965	160L	86.4	86.9	85.9	81.5	76.0	65.0	23.7	22.5	21.7	155	11.09	245	230	270	0.558	129
15	20	970	180L	87.7	88.2	87.7	82.0	79.5	73.5	31.7	30.1	29.0	178	15.05	195	140	210	1.342	181
18.5	25	975	200L	88.6	88.6	87.6	82.5	79.0	70.5	38.5	36.5	35.2	223	18.46	200	185	220	1.604	222
22	30	975	200L	89.2	89.7	89.7	82.0	78.5	69.5	45.7	43.4	41.8	296	21.95	210	180	220	1.912	242
30	40	975	225MC	90.2	90.2	87.2	86.0	83.5	76.0	58.8	55.8	53.8	344	29.94	175	155	210	2.442	285
37	50	975	250MC	90.8	90.8	89.8	85.5	81.0	73.0	72.4	68.8	66.3	451	36.92	185	180	220	3.373	354
45	60	980	280SB	91.4	91.5	90.7	82.5	79.5	71.0	90.7	86.1	83.0	597	44.68	150	140	230	4.400	443
55	75	980	280MB	91.9	92.0	91.3	83.5	80.5	72.0	109	103	99.7	680	54.61	150	140	235	5.290	490
75	100	985	315SB	92.6	92.7	92.1	84.5	81.5	72.5	146	138	133	900	74.09	160	130	230	9.323	671
90	125	985	315MB	93.0	93.0	92.5	84.5	81.5	72.0	174	165	159	1070	88.90	175	145	230	12.80	730
(110)	(150)	988	315MB	93.5	93.5	93.0	84.5	81.5	72.5	212	201	194	1295	108.3	175	145	230	15.60	810
110	150	988	315LB	93.5	93.5	93.0	84.5	81.5	72.5	212	201	194	1295	108.3	175	145	230	15.60	816
132	175	988	315LB	93.7	93.7	93.2	84.0	80.0	71.0	255	242	233	1530	130.0	210	175	240	17.20	946
(160)	(215)	988	315LB	94.0	94.0	93.4	84.8	81.6	73.5	305	290	279	1950	157.6	210	175	240	23.20	1096
160	215	988	355MB	94.0	94.0	93.4	86.0	83.0	75.0	301	286	275	2050	157.6	180	160	300	27.28	1315
(200)	(270)	988	315CB	94.2	94.2	93.8	85.5	83.0	74.0	377	358	345	2360	197.0	200	165	240	30.80	1650
200	270	988	355MB	94.2	94.2	93.8	85.5	83.0	74.0	377	358	345	2360	197.0	200	165	240	30.80	1455
(220)	(300)	988	315CB	94.5	94.5	94.0	86.5	84.5	78.0	409	388	374	2550	216.7	180	160	240	35.20	1740
220	300	988	355MB	94.5	94.5	94.0	86.5	84.5	78.0	409	388	374	2550	216.7	180	160	240	35.20	1545
(250)	(335)	988	315DB	94.6	94.6	94.2	86.5	85.0	78.5	464	441	425	2900	246.2	200	165	240	41.20	1860
250	335	988	355LB	94.6	94.6	94.2	86.5	85.0	78.5	464	441	425	2900	246.2	200	165	240	41.20	1665
315	420	990	355CB	94.8	94.8	94.4	87.5	85.5	79.0	577	548	528	3800	309.6	210	175	240	56.00	2600

Note:

1. The above are typical values based on test according to IEC 60034-2-1 :2007.(DY)
2. Tolerance according to IEC 60034-1.
3. Breakdown & Locked rotor torques are show as average expected voltages
4. Efficiency, power factor, speed and torque are the same for other voltages.
Current values vary inversely with voltage
5. Output in () is for Optional Frame size upon request
6. Frame size 315C, 315D, & 355C: only suitable for IM B3 and IM B35
7. Noise according to IEC 60034-9.
8. Data subject to change without prior notice.



IE 1 PERFORMANCE DATA (8 POLE)

Motor Type: AESV1S / AESU1S / AESV1S-LA

OUTPUT		FULL LOAD rpm	FRAME No.	EFFICIENCY			POWER FACTOR			CURRENT				TORQUE				ROTOR GD ² kg-m ²	APPROX. WEIGHT kg
kW	HP			FULL LOAD (%)	3/4 LOAD (%)	1/2 LOAD (%)	FULL LOAD (%)	3/4 LOAD (%)	1/2 LOAD (%)	FULL LOAD (A)			LRC (A)	FULL LOAD kg-m	LOCKED ROTOR %FLT	PULL-UP %FLT	BREAK-DOWN %FLT		
										VOLTAGE									
								380	400	415	400V								
0.18	0.25	710	80M	38.0	33.8	27.4	46.5	40.0	34.0	1.55	1.47	1.42	4.7	0.247	360	350	370	0.010	14.0
0.37	0.5	705	90S	49.7	47.4	42.2	61.5	52.0	41.5	1.84	1.75	1.68	5.0	0.511	180	170	240	0.017	20.0
0.55	0.75	700	90L	56.1	54.4	49.1	61.5	53.0	42.0	2.42	2.30	2.22	7.3	0.765	180	150	250	0.022	21.0
0.75	1	700	10 L	61.2	59.9	54.9	66.0	56.5	45.5	2.82	2.68	2.58	9.4	1.043	180	160	210	0.033	23.0
1.1	1.5	690	100L	66.5	66.0	62.0	67.5	59.0	47.0	3.72	3.54	3.41	15	1.551	200	175	210	0.046	28.5
1.5	2	705	11 M	70.2	69.7	66.0	67.0	59.0	46.5	4.85	4.60	4.44	20	2.070	160	135	215	0.065	35.0
2.2	3	700	132S	74.2	74.2	71.9	72.5	64.0	51.0	6.21	5.90	5.69	26	3.058	190	175	225	0.115	44.5
3	4	700	132M	77.0	77.5	75.3	73.0	65.0	52.0	8.11	7.70	7.43	34	4.170	190	175	220	0.138	49.5
3.7	5	720	160M	78.6	78.6	76.6	71.0	62.5	49.0	10.1	9.57	9.22	59	5.000	200	180	270	0.265	72.0
4	5.5	720	160M	79.2	79.5	77.4	71.5	64.0	51.5	10.7	10.2	9.83	59	5.406	200	180	270	0.265	72.0
5.5	7.5	720	160M	81.4	81.8	79.9	72.0	64.5	52.5	14.3	13.5	13.1	81	7.433	200	180	270	0.374	87.0
7.5	10	720	160L	83.1	83.6	82.0	73.5	66.5	54.5	18.7	17.7	17.1	107	10.14	200	190	270	0.530	104
11	15	725	180L	85.0	85.5	84.5	75.0	68.0	55.5	26.2	24.9	24.0	138	14.76	190	170	215	0.990	142
15	20	725	200L	86.2	86.8	85.8	76.5	70.5	59.0	34.6	32.8	31.6	164	20.13	190	170	205	1.418	196
18.5	25	730	225SC	86.9	86.9	85.9	78.0	72.0	62.0	41.5	39.4	38.0	236	24.66	185	150	200	2.093	250
22	30	730	225MC	87.4	86.9	85.5	77.0	70.5	59.0	49.7	47.2	45.5	281	29.32	200	175	210	2.442	276
30	40	730	250MC	88.3	87.8	86.3	78.5	70.5	60.0	65.8	62.5	60.2	378	39.99	190	160	210	3.475	338
37	50	735	280SB	88.8	89.2	88.6	77.5	78.5	75.0	81.7	77.6	74.8	495	48.98	130	125	210	5.553	500
45	60	735	280MB	89.2	89.6	89.1	78.0	79.2	76.0	98.3	93.4	90.0	595	59.57	135	125	210	6.760	557
55	75	735	315SB	89.7	89.7	88.8	79.0	74.3	63.3	118	112	108	700	72.81	145	125	210	8.735	681
75	100	735	315MB	90.3	90.3	89.6	80.5	76.0	66.0	157	149	144	850	99.29	160	130	220	19.60	760
90	125	735	315LB	90.7	90.7	90.0	81.0	77.0	67.5	186	177	170	1000	119.1	160	130	220	23.60	886
110	150	735	315LB	91.1	91.1	90.5	81.0	78.0	68.5	226	215	207	1250	145.6	160	130	220	30.40	986
(132)	(175)	740	315CB	91.5	91.5	90.7	79.5	74.5	60.0	276	262	252	1550	173.6	110	95	230	28.00	1550
132	175	740	355MB	91.5	91.5	90.7	79.5	74.5	60.0	276	262	252	1550	173.6	110	95	230	28.00	1355
(160)	(215)	740	315CB	91.9	91.9	91.0	80.5	75.5	65.0	329	312	301	1850	210.4	110	95	230	34.40	1650
160	215	740	355MB	91.9	91.9	91.0	80.5	75.5	65.0	329	312	301	1850	210.4	110	95	230	34.40	1455
(200)	(270)	740	315DB	92.5	92.6	91.9	81.0	76.1	65.7	406	385	371	2300	263.0	110	95	230	41.20	1800
200	270	740	355LB	92.5	92.6	91.9	81.0	76.1	65.7	406	385	371	2300	263.0	110	95	230	41.20	1605
(220)	(300)	740	315DB	92.5	92.5	92.0	80.5	75.0	64.5	449	426	411	2550	289.3	110	95	230	45.60	1900
220	300	740	355LB	92.5	92.5	92.0	80.5	75.0	64.5	449	426	411	2550	289.3	110	95	230	45.60	1705
250	335	740	355CB	92.5	92.5	92.0	83.5	80.0	71.0	492	467	450	3200	328.7	135	110	240	67.60	2400

Note:

1. The above are typical values based on test according to IEC 60034-2-1 :2007.(DY)
2. Tolerance according to IEC 60034-1.
3. Breakdown & Locked rotor torques are show as average expected voltages
4. Efficiency, power factor, speed and torque are the same for other voltages.
Current values vary inversely with voltage
5. Output in () is for Optional Frame size upon request
6. Frame size 315C, 315D, & 355C: only suitable for IM B3 and IM B5
7. Noise according to IEC 60034-9.
8. Data subject to change without prior notice.

IE 2 PERFORMANCE DATA (2 POLE)

Motor Type: AESV2S / AESU2S / AESV2S-LA



OUTPUT		FULL LOAD rpm	FRAME No.	EFFICIENCY			POWER FACTOR			CURRENT				TORQUE				ROTOR GD ² kg-m ²	APPROX. WEIGHT kg
kW	HP			FULL LOAD (%)	3/4 LOAD (%)	1/2 LOAD (%)	FULL LOAD (%)	3/4 LOAD (%)	1/2 LOAD (%)	FULL LOAD (A)			LRC (A)	FULL LOAD kg-m	LOCKED ROTOR %FLT	PULL-UP %FLT	BREAK-DOWN %FLT		
										VOLTAGE									
								380	400	415	400V								
0.75	1	2850	80M	77.4	78.0	76.3	85.5	78.5	66.0	1.72	1.64	1.58	9.0	0.256	215	180	280	0.005	13.5
1.1	1.5	2875	80M	79.6	80.0	78.3	85.5	79.0	67.0	2.46	2.33	2.25	17	0.372	255	200	305	0.007	16.5
1.5	2	2880	90	81.3	81.8	80.3	86.5	80.5	69.0	3.24	3.08	2.97	24	0.507	260	245	325	0.011	20.0
2.2	3	2875	90L	83.2	84.3	83.4	87.5	82.0	70.5	4.59	4.36	4.20	35	0.745	285	240	335	0.014	23.0
3	4	2895	100L	84.6	85.9	85.7	88.0	83.0	73.0	6.12	5.82	5.61	49	1.008	245	225	310	0.022	32.0
3.7	5	2880	112M	85.5	86.5	85.4	90.0	87.0	79.0	7.31	6.94	6.69	59	1.250	240	210	320	0.042	41.5
4	5.5	2880	112M	85.8	86.9	86.6	91.0	88.0	81.0	7.78	7.39	7.13	63	1.351	235	205	315	0.042	41.5
5.5	7.5	2925	132S	87.0	87.2	86.2	86.0	82.5	74.5	11.2	10.6	10.2	82	1.830	240	180	300	0.063	56.5
7.5	10	2920	132S	88.1	88.3	87.8	82.5	77.5	68.0	15.7	14.9	14.4	98	2.499	250	230	275	0.075	63.0
11	15	2950	160M	89.4	89.3	88.1	90.5	87.5	80.5	20.7	19.6	18.9	172	3.628	230	180	305	0.154	99.0
15	20	2930	160M	90.3	91.0	91.2	93.5	92.5	89.0	27.0	25.6	24.7	225	4.981	245	165	280	0.192	109
18.5	25	2925	160L	90.9	91.5	91.7	93.0	91.5	88.0	33.2	31.6	30.4	290	6.154	260	185	310	0.237	124
22	30	2930	180M	91.3	91.2	90.5	91.5	90.0	85.5	40.0	38.0	36.6	295	7.306	215	185	300	0.283	161
30	40	2945	200L	92.0	92.2	91.3	90.5	89.5	86.0	54.7	52.0	50.1	440	9.912	210	150	300	0.521	217
37	50	2945	200L	92.5	92.9	92.7	91.5	90.5	87.5	66.4	63.1	60.8	585	12.22	175	130	260	0.663	248
45	60	2965	225MA	92.9	92.5	91.3	91.0	88.5	82.5	80.9	76.8	74.1	710	14.77	170	140	300	1.074	280
55	75	2970	250MA	93.2	93.2	92.6	92.5	91.5	88.0	96.9	92.1	88.8	730	18.02	165	150	300	1.343	379
75	100	2960	280SA	93.8	93.6	92.8	89.0	87.5	82.0	136	130	125	1040	24.65	130	120	285	1.759	465
90	125	2970	280MA	94.1	93.9	92.8	87.5	86.0	76.0	166	158	152	1335	29.48	175	135	300	2.287	529
110	150	2970	315SA	94.3	94.1	93.0	88.0	86.3	76.4	201	191	184	1520	36.04	200	165	270	3.113	621
132	175	2975	315MA	94.6	94.3	93.4	89.5	88.0	83.0	237	225	217	1750	43.17	200	165	270	4.400	750
(160)	(215)	2975	315MA	94.8	94.5	93.5	91.0	89.5	84.5	282	268	258	2175	52.33	210	175	270	5.600	850
160	215	2975	315LA	94.8	94.5	93.5	91.0	89.5	84.5	282	268	258	2175	52.33	210	175	270	5.600	866
200	270	2975	315LA	95.0	94.8	93.8	92.0	91.0	88.5	348	330	318	2620	65.41	210	175	260	7.200	1016
(220)	(300)	2972	315CA	95.0	94.6	93.5	91.5	90.0	86.0	385	365	352	2750	72.03	140	120	280	7.600	1420
220	300	2972	355MA	95.0	94.6	93.5	91.5	90.0	86.0	385	365	352	2750	72.03	140	120	280	7.600	1225
(250)	(335)	2972	315CA	95.0	94.6	93.4	92.0	91.0	88.0	435	413	398	3100	81.85	140	120	280	8.400	1540
250	335	2972	355MA	95.0	94.6	93.4	92.0	91.0	88.0	435	413	398	3100	81.85	140	120	280	8.400	1345
(315)	(420)	2975	315DA	95.2	94.8	93.6	92.5	91.5	89.0	543	516	498	3900	103.0	150	135	280	10.80	1760
315	420	2975	355LA	95.2	94.8	93.6	92.5	91.5	89.0	543	516	498	3900	103.0	150	135	280	10.80	1565
375	500	2978	355CA	95.3	95.0	94.4	91.0	90.0	86.0	657	624	602	4500	122.5	150	125	280	16.00	2400

Note:

1. The above are typical values based on test according to IEC 60034-2-1 :2007.(DY)
2. Tolerance according to IEC 60034-1.
3. Breakdown & Locked rotor torques are show as average expected voltages
4. Efficiency, power factor, speed and torque are the same for other voltages.
Current values vary inversely with voltage
5. Output in () is for Optional Frame size upon request
6. Frame size 315C, 315D, & 355C: only suitable for IM B3 and IM B5
7. Noise according to IEC 60034-9.
8. Data subject to change without prior notice.



IE 2 PERFORMANCE DATA (4 POLE)

Motor Type: AESV2S / AESU2S / AESV2S-LA

OUTPUT		FULL LOAD	FRAME No.	EFFICIENCY			POWER FACTOR			CURRENT				TORQUE				ROTOR GD ²	APPROX. WEIGHT
				FULL LOAD	3/4 LOAD	1/2 LOAD	FULL LOAD	3/4 LOAD	1/2 LOAD	FULL LOAD (A)			LRC (A)	FULL LOAD	LOCKED ROTOR	PULL-UP	BREAK-DOWN		
										VOLTAGE									
kW	HP	rpm	(%)	(%)	(%)	(%)	(%)	(%)	380	400	415	400V	kg-m	%FLT	%FLT	%FLT	kg-m ²	kg	
0.55	0.75	1425	80M	78.1	78.0	75.1	72.5	62.0	47.5	1.48	1.40	1.35	8.0	0.376	290	260	305	0.010	14.5
0.75	1	1415	80M	79.6	79.5	76.9	73.5	63.5	49.5	1.95	1.85	1.78	11	0.516	300	295	325	0.013	17.5
1.1	1.5	1445	90S	81.4	81.4	78.9	76.0	67.0	53.0	2.70	2.57	2.47	19	0.741	270	205	325	0.017	21.0
1.5	2	1435	90L	82.8	83.7	82.6	81.0	73.0	59.5	3.40	3.23	3.11	23	1.017	250	180	300	0.022	22.5
2.2	3	1450	100L	84.3	85.0	84.1	81.5	74.0	61.0	4.87	4.62	4.45	33	1.476	210	170	300	0.041	31.0
3	4	1445	100L	85.5	85.9	84.8	82.0	75.0	62.5	6.50	6.18	5.95	44	2.020	210	170	300	0.050	34.0
3.7	5	1435	112M	86.3	87.0	87.0	85.0	81.6	72.7	7.66	7.28	7.02	60	2.509	220	150	290	0.081	44.0
4	5.5	1450	112M	86.6	87.6	87.5	85.0	80.5	71.0	8.26	7.84	7.56	58	2.684	220	200	300	0.081	47.0
5.5	7.5	1455	132S	87.7	88.7	88.6	85.5	80.5	70.0	11.1	10.6	10.2	81	3.678	255	210	305	0.123	61.0
7.5	10	1460	132M	88.7	89.6	89.5	84.0	78.5	67.0	15.3	14.5	14.0	112	4.998	275	200	305	0.142	71.5
11	15	1465	160M	89.8	90.6	90.7	86.5	83.0	74.5	21.5	20.4	19.7	160	7.306	220	180	300	0.296	104
15	20	1470	160L	90.6	91.3	91.2	86.5	82.5	73.5	29.1	27.6	26.6	220	9.929	220	185	300	0.427	128
18.5	25	1475	180M	91.2	91.7	91.6	85.5	83.0	76.5	36.0	34.2	33.0	230	12.20	200	185	300	0.654	166
22	30	1470	180L	91.6	92.4	92.2	85.5	83.5	77.5	42.7	40.5	39.1	270	14.56	195	155	250	0.770	185
30	40	1470	200L	92.3	92.9	92.9	87.5	84.5	77.0	56.4	53.6	51.7	420	19.86	230	180	300	1.217	227
37	50	1475	225SC	92.7	93.3	93.3	87.5	86.0	80.0	69.3	65.8	63.5	430	24.41	220	175	260	1.649	288
45	60	1480	225MC	93.1	93.3	92.9	86.0	82.5	75.0	85.4	81.1	78.2	580	29.58	210	170	300	1.979	315
55	75	1485	250MC	93.5	93.7	93.3	87.5	85.0	79.0	102	97.0	93.5	780	36.04	245	180	300	3.621	404
75	100	1480	280SB	94.0	94.0	93.2	87.0	84.0	77.5	139	132	128	1015	49.31	185	170	300	4.853	547
90	125	1480	280MB	94.2	94.0	93.2	85.5	82.5	75.5	170	161	155	1260	59.17	200	190	280	5.393	581
110	150	1484	315SB	94.5	94.5	93.8	88.5	85.8	78.8	200	190	183	1400	72.12	200	165	270	7.582	671
132	175	1484	315MB	94.7	94.7	94.0	88.5	86.0	79.0	239	227	219	1620	86.55	200	165	270	10.00	820
(160)	(215)	1485	315MB	94.9	94.9	94.2	88.5	87.0	80.0	289	275	265	2000	104.8	210	175	270	11.60	920
160	215	1485	315LB	94.9	94.9	94.2	88.5	87.0	80.0	289	275	265	2000	104.8	210	175	270	11.60	926
200	270	1485	315LB	95.1	95.1	94.6	88.5	86.0	79.5	361	343	331	2500	131.0	200	165	270	14.40	1056
(220)	(300)	1485	315CB	95.1	95.1	94.4	90.0	89.0	84.0	391	371	358	2800	144.1	210	175	260	22.00	1500
220	300	1485	355MB	95.1	95.1	94.4	90.0	89.0	84.0	391	371	358	2800	144.1	210	175	260	22.00	1305
(250)	(335)	1485	315CB	95.1	95.1	94.4	90.0	89.0	84.5	444	422	406	3100	163.8	210	175	260	24.00	1620
250	335	1485	355MB	95.1	95.1	94.4	90.0	89.0	84.5	444	422	406	3100	163.8	210	175	260	24.00	1425
(315)	(420)	1485	315DB	95.1	95.1	94.6	89.5	87.5	81.5	562	534	515	4100	206.4	210	175	260	26.40	1820
315	420	1485	355LB	95.1	95.1	94.6	89.5	87.5	81.5	562	534	515	4100	206.4	210	175	260	26.40	1625
375	500	1488	355CB	95.3	95.3	94.8	89.5	87.5	81.5	668	635	612	4450	245.2	200	165	270	34.40	2400

Note:

1. The above are typical values based on test according to IEC 60034-2-1 :2007.(DY)
2. Tolerance according to IEC 60034-1.
3. Breakdown & Locked rotor torques are show as average expected voltages
4. Efficiency, power factor, speed and torque are the same for other voltages.
Current values vary inversely with voltage
5. Output in () is for Optional Frame size upon request
6. Frame size 315C, 315D, & 355C: only suitable for IM B3 and IM B35
7. Noise according to IEC 60034-9.
8. Data subject to change without prior notice.

IE 2 PERFORMANCE DATA (6 POLE)

Motor Type: AESV2S / AESU2S / AESV2S-LA



OUTPUT		FULL LOAD rpm	FRAME No.	EFFICIENCY			POWER FACTOR			CURRENT				TORQUE			ROTOR GD ² kg-m ²	APPROX. WEIGHT kg	
kW	HP			FULL LOAD (%)	3/4 LOAD (%)	1/2 LOAD (%)	FULL LOAD (%)	3/4 LOAD (%)	1/2 LOAD (%)	FULL LOAD (A)			LRC (A) 400V	FULL LOAD kg-m	LOCKED ROTOR %FLT	PULL-UP %FLT			BREAK-DOWN %FLT
										VOLTAGE									
					380	400	415												
0.55	0.75	900	80M	73.1	68.8	64.9	67.0	57.0	44.0	1.82	1.73	1.67	7.0	0.595	225	220	250	0.012	15.0
0.75	1	935	90S	75.9	76.4	73.9	69.5	60.0	46.5	2.16	2.05	1.98	10	0.780	210	185	260	0.019	22.0
1.1	1.5	930	90L	78.1	78.8	76.9	71.5	62.0	48.5	2.99	2.84	2.74	14	1.151	215	190	260	0.026	25.0
1.5	2	950	100L	79.8	80.5	78.8	70.5	61.5	48.5	4.05	3.85	3.71	19	1.536	170	140	240	0.048	33.0
2.2	3	950	112M	81.8	82.4	81.1	75.0	66.5	53.0	5.45	5.18	4.99	34	2.253	280	255	300	0.071	41.0
3	4	960	132S	83.3	84.1	83.2	78.0	71.0	58.0	7.02	6.66	6.42	37	3.041	190	165	300	0.103	49.5
3.7	5	965	132M	84.3	84.3	82.8	76.0	68.5	55.0	8.78	8.34	8.04	61	3.731	180	180	270	0.131	52.5
4	5.5	960	132M	84.6	85.6	85.1	79.0	72.5	60.0	9.09	8.64	8.33	53	4.054	210	180	300	0.131	58.5
5.5	7.5	960	132M	86.0	86.9	86.5	79.5	72.5	60.5	12.2	11.6	11.2	78	5.574	230	195	300	0.188	71.5
7.5	10	960	160M	87.2	88.2	87.7	82.0	77.0	66.5	15.9	15.1	14.6	105	7.602	210	195	260	0.363	99.0
11	15	965	160L	88.7	89.2	88.6	81.5	76.0	65.0	23.1	22.0	21.2	170	11.09	245	205	300	0.558	128
15	20	975	180L	89.7	90.4	90.2	82.5	77.5	67.5	30.8	29.3	28.2	220	14.97	210	195	300	1.337	188
18.5	25	975	200L	90.4	91.0	90.9	79.5	75.0	65.5	39.1	37.2	35.8	260	18.46	215	195	300	1.604	222
22	30	980	200L	90.9	91.4	91.8	81.0	77.5	68.5	45.4	43.1	41.6	300	21.84	210	180	255	1.912	242
30	40	980	225MC	91.7	92.4	92.2	86.0	83.0	76.0	57.8	54.9	52.9	365	29.79	210	190	285	2.442	295
37	50	980	250MC	92.2	92.3	91.7	86.5	83.0	74.0	70.5	67.0	64.5	455	36.74	210	185	275	3.373	359
45	60	985	280SB	92.7	92.5	91.3	80.5	75.0	64.5	91.6	87.0	83.9	600	44.45	200	185	300	5.290	485
55	75	985	280MB	93.1	93.0	92.1	82.5	78.0	68.0	109	103	99.6	700	54.33	195	185	295	6.492	543
75	100	985	315SB	93.7	93.7	92.8	84.0	80.5	70.5	145	138	133	950	74.09	200	165	240	9.945	691
90	125	987	315MB	94.0	94.0	93.1	84.0	81.0	71.0	173	165	159	1070	88.72	200	165	240	12.80	790
(110)	(150)	988	315MB	94.3	94.3	93.7	85.0	82.0	73.0	209	198	191	1370	108.3	200	165	250	16.40	910
110	150	988	315LB	94.3	94.3	93.7	85.0	82.0	73.0	209	198	191	1370	108.3	200	165	250	16.40	916
132	175	988	315LB	94.6	94.6	94.0	85.0	82.0	73.0	249	237	228	1500	130.0	200	165	250	18.40	996
(160)	(215)	988	315LB	94.8	94.8	94.0	85.0	82.0	74.0	302	287	276	1880	157.6	210	175	250	23.20	1076
160	215	988	355MB	94.8	94.8	94.2	85.5	82.2	74.2	300	285	275	2050	157.6	200	165	250	30.31	1385
(200)	(270)	988	315CB	95.0	95.0	94.2	86.0	85.5	82.0	372	353	341	2400	197.0	200	165	250	33.60	1720
200	270	988	355MB	95.0	95.0	94.2	86.0	85.5	82.0	372	353	341	2400	197.0	200	165	250	33.60	1525
(220)	(300)	988	315CB	95.0	95.0	94.4	86.5	84.5	78.0	407	386	372	2750	216.7	200	165	250	36.40	1800
220	300	988	355MB	95.0	95.0	94.4	86.5	84.5	78.0	407	386	372	2750	216.7	200	165	250	36.40	1605
(250)	(335)	988	315DB	95.0	95.0	94.6	86.5	84.0	77.0	462	439	423	3000	246.2	200	165	250	42.00	1900
250	335	988	355LB	95.0	95.0	94.6	86.5	84.0	77.0	462	439	423	3000	246.2	200	165	250	42.00	1705
315	420	988	355CB	95.2	95.2	94.8	87.0	85.0	78.0	578	549	529	3700	310.2	200	165	250	55.60	2650

Note:

1. The above are typical values based on test according to IEC 60034-2-1 :2007.(DY)
2. Tolerance according to IEC 60034-1.
3. Breakdown & Locked rotor torques are show as average expected voltages
4. Efficiency, power factor, speed and torque are the same for other voltages.
Current values vary inversely with voltage
5. Output in () is for Optional Frame size upon request
6. Frame size 315C, 315D, & 355C: only suitable for IM B3 and IM B35
7. Noise according to IEC 60034-9.
8. Data subject to change without prior notice.



IE 2 PERFORMANCE DATA (8 POLE)

Motor Type: AESV2S / AESU2S / AESV2S-LA

OUTPUT		FULL LOAD rpm	FRAME No.	EFFICIENCY			POWER FACTOR			CURRENT				TORQUE				ROTOR GD ² kg-m ²	APPROX. WEIGHT kg
				FULL LOAD (%)	3/4 LOAD (%)	1/2 LOAD (%)	FULL LOAD (%)	3/4 LOAD (%)	1/2 LOAD (%)	FULL LOAD (A)			LRC (A)	FULL LOAD kg-m	LOCKED ROTOR %FLT	PULL-UP %FLT	BREAK-DOWN %FLT		
										VOLTAGE									
kW	HP									380	400	415	400V						
0.18	0.25	710	80M	45.9	40.9	33.0	46.5	40.0	34.0	1.28	1.22	1.17	4.7	0.247	360	350	370	0.010	13.9
0.37	0.5	710	90S	56.1	53.5	46.9	60.0	51.0	41.0	1.67	1.59	1.53	5.7	0.507	200	185	270	0.017	20.0
0.55	0.75	695	90L	61.7	62.2	58.9	70.0	61.0	48.5	1.93	1.84	1.77	7.3	0.770	180	140	220	0.023	22.0
0.75	1	695	100L	66.2	65.5	62.7	65.0	56.0	43.5	2.65	2.52	2.42	10	1.050	210	175	235	0.046	32.0
1.1	1.5	690	100L	70.8	71.1	69.2	67.5	58.5	45.5	3.50	3.32	3.20	14	1.551	210	175	230	0.059	37.3
1.5	2	700	112M	74.1	74.3	72.8	66.0	57.0	45.0	4.66	4.43	4.27	18	2.085	200	150	225	0.071	40.9
2.2	3	710	132S	77.6	80.1	77.7	64.5	55.0	42.0	6.68	6.34	6.11	31	3.015	240	235	300	0.138	54.0
3	4	700	132M	80.0	81.7	80.2	69.0	59.5	46.0	8.26	7.84	7.56	37	4.170	215	210	270	0.162	62.0
3.7	5	725	160M	81.4	81.5	80.0	69.0	59.5	46.0	10.0	9.51	9.16	51	4.966	200	180	260	0.343	97.0
4	5.5	715	160M	81.9	82.9	80.9	71.5	63.0	51.0	10.4	9.86	9.50	55	5.443	185	160	270	0.343	97.0
5.5	7.5	715	160M	83.8	83.3	81.8	71.0	63.0	51.0	14.0	13.3	12.9	70	7.485	185	160	265	0.343	99.0
7.5	10	720	160L	85.3	85.3	83.3	70.0	61.0	49.0	19.1	18.1	17.5	105	10.14	210	180	300	0.586	134
11	15	720	180L	86.9	86.7	86.2	70.0	62.0	56.0	27.5	26.1	25.2	140	14.87	210	160	230	1.019	164
15	20	720	200L	88.0	89.0	90.0	77.0	71.5	64.5	33.6	32.0	30.8	165	20.27	185	140	205	1.749	231
18.5	25	735	225SC	88.6	89.1	88.1	72.0	65.5	58.0	44.1	41.9	40.3	220	24.49	210	185	235	2.675	292
22	30	735	225MC	89.1	89.1	89.1	74.5	69.0	63.0	50.4	47.8	46.1	240	29.12	210	170	215	3.023	322
30	40	735	250MC	89.8	89.8	89.8	74.5	68.0	58.0	68.1	64.7	62.4	350	39.71	210	170	245	4.565	405
37	50	735	280SB	90.3	90.7	90.1	77.5	78.5	75.0	80.3	76.3	73.6	496	48.98	130	125	210	5.553	489
45	60	735	280MB	90.7	91.1	90.6	78.0	79.2	76.0	96.6	91.8	88.5	597	59.57	135	125	210	6.760	546
55	75	735	315SB	91.0	90.9	89.9	81.0	76.0	66.0	113	108	104	720	72.81	140	120	275	89.90	691
75	100	737	315MB	91.6	91.8	91.3	81.0	78.0	70.0	154	146	141	786	99.02	140	120	205	91.30	850
90	125	737	315LB	91.9	92.0	91.4	81.0	78.0	69.0	184	175	168	967	118.8	150	130	210	91.40	986
110	150	737	315LB	92.3	92.4	91.7	81.0	78.5	69.0	224	212	205	1205	145.2	155	135	215	91.70	1026
(132)	(175)	737	315CB	92.6	92.8	92.3	81.0	77.0	67.0	267	254	245	1739	174.3	135	120	275	29.55	1580
132	175	737	355MB	92.6	92.8	92.3	81.0	77.0	67.0	267	254	245	1739	174.3	135	120	275	29.55	1385
(160)	(215)	737	315CB	93.0	93.3	93.0	81.0	78.0	69.0	323	307	295	2031	211.2	130	115	265	34.85	1690
160	215	737	355MB	93.0	93.3	93.0	81.0	78.0	69.0	323	307	295	2031	211.2	130	115	265	34.85	1495
(200)	(270)	737	315DB	93.5	93.7	93.5	82.5	79.0	71.0	394	374	361	2621	264.0	135	120	270	53.04	1850
200	270	737	355LB	93.5	93.7	93.5	82.5	79.0	71.0	394	374	361	2621	264.0	135	120	270	53.04	1655
(220)	(300)	737	315DB	93.5	93.8	93.7	83.0	81.0	73.0	431	409	394	2634	290.4	120	105	245	58.34	1960
220	300	737	355LB	93.5	93.8	93.7	83.0	81.0	73.0	431	409	394	2634	290.4	120	105	245	58.34	1765
250	335	739	355CB	93.5	93.5	93.0	83.0	80.0	71.0	489	465	448	3110	329.2	130	115	270	64.61	2500

Note:

1. The above are typical values based on test according to IEC 60034-2-1 :2007.(DY)
2. Tolerance according to IEC 60034-1.
3. Breakdown & Locked rotor torques are show as average expected voltages
4. Efficiency, power factor, speed and torque are the same for other voltages.
Current values vary inversely with voltage
5. Output in () is for Optional Frame size upon request
6. Frame size 315C, 315D, & 355C: only suitable for IM B3 and IM B5
7. Noise according to IEC 60034-9.
8. Data subject to change without prior notice.

IE 3 PERFORMANCE DATA (2 POLE)

Motor Type: AESV3S / AESU3S / AESV3S-LA



OUTPUT		FULL LOAD rpm	FRAME No.	EFFICIENCY			POWER FACTOR			CURRENT				TORQUE			ROTOR GD ² kg-m ²	APPROX. WEIGHT kg	
kW	HP			FULL LOAD (%)	3/4 LOAD (%)	1/2 LOAD (%)	FULL LOAD (%)	3/4 LOAD (%)	1/2 LOAD (%)	FULL LOAD (A)			LRC (A) 400V	FULL LOAD kg-m	LOCKED ROTOR %FLT	PULL-UP %FLT			BREAK-DOWN %FLT
										VOLTAGE									
								380	400	415									
0.75	1	2875	M	80.7	78.3	75.1	84.5	78.0	66.5	1.67	1.59	1.53	12	0.254	280	275	335	0.006	17.0
1.1	1.5	2870	80M	82.7	83.0	81.3	85.0	78.5	66.5	2.38	2.26	2.18	18	0.373	300	295	350	0.007	18.5
1.5	2	2850	9	84.2	85.4	85.8	90.5	87.0	78.0	2.99	2.84	2.74	22	0.512	220	210	300	0.012	25.0
2.2	3	2860	90L	85.9	86.7	86.8	89.5	85.0	75.5	4.35	4.13	3.98	35	0.748	245	235	315	0.014	27.5
3	4	2855	100L	87.1	88.3	88.4	90.0	86.5	78.5	5.81	5.52	5.32	48	1.022	325	310	355	0.025	37.9
3.7	5	2870	112M	87.8	88.2	88.0	90.5	87.5	80.0	7.07	6.72	6.48	60	1.254	290	270	345	0.046	48.0
4	5.5	2875	112M	88.1	89.0	88.9	91.0	87.5	80.0	7.58	7.20	6.94	69	1.354	270	250	360	0.046	48.0
5.5	7.5	2930	132S	89.2	89.8	89.5	86.0	83.6	77.3	10.9	10.3	9.97	80	1.826	210	205	340	0.075	67.5
7.5	10	2920	132S	90.1	90.9	90.8	87.0	84.5	77.5	14.5	13.8	13.3	100	2.499	210	195	315	0.081	69.5
11	15	2935	160M	91.2	92.0	92.0	90.0	89.0	83.5	20.4	19.3	18.6	148	3.647	230	185	300	0.183	116
15	20	2935	160M	91.9	92.0	92.0	89.0	85.5	77.5	27.9	26.5	25.5	204	4.973	275	230	330	0.205	119
18.5	25	2930	160L	92.4	93.0	93.0	90.0	89.5	84.0	33.8	32.1	30.9	247	6.144	245	200	300	0.237	128
22	30	2940	180M	92.7	92.7	92.5	87.0	85.0	77.0	41.4	39.4	38.0	300	7.281	225	180	300	0.283	166
30	40	2950	200L	93.3	93.5	92.5	90.0	90.0	86.5	54.3	51.6	49.7	376	9.895	200	145	300	0.602	237
37	50	2955	200L	93.7	94.5	94.0	91.0	90.5	87.0	65.9	62.6	60.4	482	12.18	210	145	300	0.753	272
45	60	2960	225MA	94.0	94.0	93.5	91.0	91.0	88.0	79.9	75.9	73.2	585	14.79	170	140	300	1.187	300
55	75	2970	250MA	94.3	94.5	94.0	91.5	90.0	86.5	96.8	92.0	88.7	708	18.02	165	130	315	1.544	414
75	100	2970	280SA	94.7	94.6	93.6	90.0	89.8	87.6	134	127	122	978	24.57	155	135	300	1.935	496
90	125	2970	280MA	95.0	95.0	94.0	90.5	90.0	82.5	159	151	146	1163	29.48	150	135	285	2.463	553
110	150	2980	315SA	95.2	95.2	94.3	90.5	89.2	83.2	194	184	178	1419	35.92	200	165	240	3.336	800
132	175	2980	315MA	95.4	95.3	94.5	90.5	89.5	87.0	232	221	213	1699	43.10	200	165	240	4.800	822
(160)	(215)	2980	315MA	95.6	95.5	94.8	91.0	90.0	86.5	279	265	256	2044	52.24	200	165	250	5.200	880
160	215	2980	315LA	95.6	95.5	94.8	91.0	90.0	86.5	279	265	256	2044	52.24	200	165	250	5.200	876
200	270	2980	315LA	95.8	95.8	95.2	91.5	90.5	87.5	347	329	317	2536	65.30	200	165	250	7.200	1006
(220)	(300)	2980	315CA	95.8	95.6	95.0	90.0	88.5	83.5	388	368	355	2750	71.83	180	150	230	8.400	1520
220	300	2980	355MA	95.8	95.6	95.0	90.0	88.5	83.5	388	368	355	2750	71.83	180	150	230	8.400	1325
(250)	(335)	2980	315CA	95.8	95.6	95.0	91.0	89.5	85.5	436	414	399	3000	81.63	180	150	235	10.00	1660
250	335	2980	355MA	95.8	95.6	95.0	91.0	89.5	85.5	436	414	399	3000	81.63	180	150	235	10.00	1465
(315)	(420)	2980	315DA	95.8	95.6	95.0	91.0	90.0	86.0	549	522	503	3900	102.9	180	150	240	11.20	1780
315	420	2980	355LA	95.8	95.6	95.0	91.0	90.0	86.0	549	522	503	3900	102.9	180	150	240	11.20	1585
375	500	2980	355CA	95.8	95.6	94.7	92.5	91.0	87.0	643	611	589	4703	122.4	150	125	280	16.00	2500

Note:

1. The above are typical values based on test according to IEC 60034-2-1 :2007.(DY)
2. Tolerance according to IEC 60034-1.
3. Breakdown & Locked rotor torques are show as average expected voltages
4. Efficiency, power factor, speed and torque are the same for other voltages.
Current values vary inversely with voltage
5. Output in () is for Optional Frame size upon request
6. Frame size 315C, 315D, & 355C: only suitable for IM B3 and IM B35
7. Noise according to IEC 60034-9.
8. Data subject to change without prior notice.



IE 3 PERFORMANCE DATA (4 POLE)

Motor Type: AESV3S / AESU3S / AESV3S-LA

OUTPUT		FULL LOAD rpm	FRAME No.	EFFICIENCY			POWER FACTOR			CURRENT				TORQUE				ROTOR GD ² kg-m ²	APPROX. WEIGHT kg
				FULL LOAD (%)	3/4 LOAD (%)	1/2 LOAD (%)	FULL LOAD (%)	3/4 LOAD (%)	1/2 LOAD (%)	FULL LOAD (A)			LRC (A)	FULL LOAD kg-m	LOCKED ROTOR %FLT	PULL-UP %FLT	BREAK-DOWN %FLT		
										VOLTAGE									
KW	HP									380	400	415	400V						
0.55	0.75	1430	80M	80.8	77.9	74.7	69.0	58.5	44.5	1.53	1.46	1.40	9.0	0.374	300	270	320	0.010	16.5
0.75		1410	80M	82.5	81.8	79.7	73.5	64.0	50.0	1.88	1.79	1.72	11	0.518	315	290	335	0.013	17.0
1.1	1.5	1430	90S	84.1	84.4	83.2	79.5	71.5	57.5	2.50	2.37	2.29	17	0.748	255	205	300	0.019	25.0
1.5	2	1435	90L	85.3	84.1	82.2	75.0	65.5	51.5	3.56	3.38	3.26	26	1.017	300	235	335	0.023	26.5
2.2	3	1450	100L	86.7	87.3	86.9	81.0	73.5	60.5	4.76	4.52	4.36	33	1.476	210	160	300	0.045	40.0
3	4	1455	100L	87.7	87.7	86.2	78.0	70.5	57.5	6.66	6.33	6.10	49	2.006	250	240	335	0.052	42.0
3.7	5	1445	112M	88.4	89.1	88.8	82.0	77.0	66.0	7.76	7.37	7.10	60	2.491	235	200	305	0.083	51.0
4	5.5	1445	112M	88.6	88.4	87.9	82.0	76.5	65.5	8.37	7.95	7.66	57	2.693	245	205	300	0.083	51.0
5.5	7.5	1455	132S	89.6	90.4	90.3	85.0	80.5	70.0	11.0	10.4	10.0	77	3.678	240	200	300	0.132	68.5
7.5	10	1460	132M	90.4	90.8	90.4	85.0	80.0	73.0	14.8	14.1	13.6	110	4.998	270	225	330	0.172	79.5
11	15	1460	160M	91.4	92.0	91.5	85.0	81.0	71.0	21.5	20.4	19.7	151	7.331	230	185	300	0.366	119
15	20	1460	160L	92.1	92.5	92.5	85.0	81.5	71.4	29.1	27.7	26.7	207	9.997	250	195	300	0.460	139
18.5	25	1475	180M	92.6	94.0	93.0	85.0	82.4	75.0	35.7	33.9	32.7	264	12.20	215	160	280	0.704	181
22	30	1475	180L	93.0	93.5	93.0	85.0	81.9	74.1	42.3	40.2	38.7	315	14.51	210	145	275	0.789	190
30	40	1470	200L	93.6	94.5	94.5	86.0	84.5	77.0	56.6	53.8	51.8	403	19.86	250	205	300	1.451	257
37	50	1480	225SC	93.9	94.5	94.0	85.5	82.0	73.0	70.0	66.5	64.1	499	24.33	210	175	300	1.896	312
45	60	1480	225MC	94.2	94.5	94.0	85.0	80.0	70.4	85.4	81.1	78.2	600	29.58	210	175	300	1.979	320
55	75	1485	250MC	94.6	94.6	94.0	87.5	84.5	77.0	101	95.9	92.4	719	36.04	210	185	295	3.911	429
75	100	1480	280SB	95.0	95.0	94.5	85.0	82.0	73.0	141	134	129	1030	49.31	160	150	300	5.033	564
90	125	1480	280MB	95.2	95.2	94.7	85.0	81.0	71.3	169	161	155	1236	59.17	175	165	300	6.112	639
110	150	1484	315SB	95.4	95.5	95.1	89.0	87.0	80.5	197	187	180	1400	72.12	200	165	270	8.056	850
132	175	1484	315MB	95.6	95.6	95.2	89.0	87.5	82.0	236	224	216	1700	86.55	200	165	270	10.40	862
(160)	(215)	1485	315MB	95.8	95.8	95.5	89.5	88.0	82.0	284	269	260	2050	104.8	200	165	260	11.60	902
160	215	1485	315LB	95.8	95.8	95.5	89.5	88.0	82.0	284	269	260	2050	104.8	200	165	260	11.60	916
200	270	1485	315LB	96.0	96.0	95.8	90.0	89.0	84.5	352	334	322	2500	131.0	200	165	260	14.00	1106
(220)	(300)	1488	315CB	96.0	95.9	95.2	86.0	82.0	72.0	405	385	371	2800	143.9	200	165	260	24.00	1640
220	300	1488	355MB	96.0	95.9	95.2	86.0	82.0	72.0	405	385	371	2800	143.9	200	165	260	24.00	1445
(250)	(335)	1488	315CB	96.0	96.0	95.4	86.5	83.5	75.0	457	435	419	3100	163.5	200	165	260	26.00	1740
250	335	1488	355MB	96.0	96.0	95.4	86.5	83.5	75.0	457	435	419	3100	163.5	200	165	260	26.00	1697
(315)	(420)	1488	315DB	96.0	96.0	95.5	86.5	83.5	75.0	576	548	528	3900	206.0	200	165	260	29.20	1940
315	420	1488	355LB	96.0	96.0	95.5	86.5	83.5	75.0	576	548	528	3900	206.0	200	165	260	29.20	1745
375	500	1488	355CB	96.0	96.0	95.5	89.5	87.0	81.0	663	630	607	4570	245.2	200	165	270	35.60	2500

Note:

1. The above are typical values based on test according to IEC 60034-2-1 :2007.(DY)
2. Tolerance according to IEC 60034-1.
3. Breakdown & Locked rotor torques are show as average expected voltages
4. Efficiency, power factor, speed and torque are the same for other voltages.
Current values vary inversely with voltage
5. Output in () is for Optional Frame size upon request
6. Frame size 315C, 315D, & 355C: only suitable for IM B3 and IM B35
7. Noise according to IEC 60034-9.
8. Data subject to change without prior notice.

IE 3 PERFORMANCE DATA (6 POLE)

Motor Type: AESV3S / AESU3S / AESV3S-LA



OUTPUT		FULL LOAD rpm	FRAME No.	EFFICIENCY			POWER FACTOR			CURRENT				TORQUE			ROTOR GD ² kg-m ²	APPROX. WEIGHT kg	
kW	HP			FULL LOAD (%)	3/4 LOAD (%)	1/2 LOAD (%)	FULL LOAD (%)	3/4 LOAD (%)	1/2 LOAD (%)	FULL LOAD (A)			LRC (A)	FULL LOAD kg-m	LOCKED ROTOR %FLT	PULL-UP %FLT			BREAK-DOWN %FLT
										VOLTAGE									
								380	400	415	400V								
0.55	0.75	905	80M	77.2	69.7	66.2	69.0	58.0	44.5	1.73	1.64	1.58	6.0	0.591	210	195	250	0.012	18.5
0.75	1	935	90S	78.9	80.6	79.4	71.0	62.5	49.0	2.03	1.93	1.86	9.0	0.780	210	190	250	0.022	26.0
1.1	1.5	930	90L	81.0	81.2	80.5	72.0	63.5	50.0	2.87	2.72	2.62	13	1.151	210	185	240	0.026	29.5
1.5	2	950	10 L	82.5	82.9	81.5	72.5	65.0	52.0	3.81	3.62	3.49	18	1.536	210	175	250	0.058	40.0
2.2	3	960	112M	84.3	84.3	82.2	67.0	59.0	47.0	5.92	5.62	5.42	29	2.230	190	180	280	0.083	50.0
3	4	970	132S	85.6	86.1	85.1	76.0	69.0	58.5	7.01	6.66	6.42	41	3.009	195	170	300	0.137	68.5
3.7	5	965	132M	86.5	87.5	87.0	77.0	70.0	58.0	8.44	8.02	7.73	56	3.731	200	185	275	0.182	75.0
4	5.5	970	132M	86.8	87.0	85.6	77.0	70.0	57.5	9.09	8.64	8.33	58	4.012	200	185	310	0.182	83.0
5.5	7.5	970	132M	88.0	88.5	87.6	79.5	72.5	60.0	11.9	11.3	10.9	88	5.517	210	205	300	0.216	84.0
7.5	10	970	160M	89.1	90.0	89.0	79.0	73.0	61.0	16.2	15.4	14.8	110	7.523	235	210	300	0.483	124
11	15	970	160L	90.3	91.0	90.5	78.0	72.0	60.5	23.7	22.5	21.7	168	11.03	295	255	300	0.628	138
15	20	970	180L	91.2	92.0	92.0	82.0	78.0	68.0	30.5	29.0	27.9	200	15.05	215	165	255	1.337	190
18.5	25	975	200L	91.7	92.5	92.5	80.5	76.0	66.5	38.1	36.2	34.9	260	18.46	220	185	265	1.829	242
22	30	975	200L	92.2	93.0	93.5	81.5	77.0	68.0	44.5	42.3	40.7	305	21.95	210	185	265	2.078	262
30	40	980	225MC	92.9	93.5	93.5	83.5	80.0	76.5	58.8	55.8	53.8	335	29.79	210	160	240	3.023	345
37	50	980	250MC	93.3	94.0	94.0	85.0	81.5	75.0	70.9	67.3	64.9	490	36.74	230	200	280	4.194	409
45	60	985	280SB	93.7	93.7	93.0	81.5	77.5	67.5	89.5	85.1	82.0	587	44.45	185	175	285	5.530	504
55	75	985	280MB	94.1	94.1	93.5	83.0	80.0	71.0	107	102	98.0	700	54.33	185	175	300	6.733	568
75	100	985	315SB	94.6	94.7	94.1	85.0	82.0	72.5	142	135	130	930	74.09	200	165	240	9.945	741
90	125	987	315MB	94.9	94.9	94.5	85.5	83.0	75.5	169	160	154	1200	88.72	200	165	240	15.20	822
(110)	(150)	988	315MB	95.1	95.1	94.7	85.5	83.0	75.5	206	195	188	1400	108.3	200	165	240	18.40	922
110	150	988	315LB	95.1	95.1	94.7	85.5	83.0	75.5	206	195	188	1400	108.3	200	165	240	18.40	976
132	175	988	315LB	95.4	95.4	95.0	85.0	82.7	75.0	247	235	226	1650	130.0	200	165	240	20.40	1096
(160)	(215)	988	315LB	95.6	95.6	95.2	85.0	82.0	74.0	299	284	274	2000	157.6	200	165	250	23.20	1136
160	215	988	355MB	95.6	95.6	95.1	86.0	83.0	74.0	296	281	271	2000	157.6	170	145	250	35.61	1445
(200)	(270)	988	315CB	95.8	95.8	95.2	86.0	83.0	74.5	369	350	338	2500	197.0	170	145	250	40.66	1780
200	270	988	355MB	95.8	95.8	95.2	86.0	83.0	74.5	369	350	338	2500	197.0	170	145	250	40.66	1585
(220)	(300)	988	315CB	95.8	95.8	95.4	86.5	84.0	76.0	403	383	369	2800	216.7	170	145	250	43.68	1860
220	300	988	355MB	95.8	95.8	95.4	86.5	84.0	76.0	403	383	369	2800	216.7	170	145	250	43.68	1665
(250)	(335)	988	315DB	95.8	95.8	95.4	86.5	83.5	75.0	458	435	420	3250	246.2	170	145	250	46.69	1960
250	335	988	355LB	95.8	95.8	95.4	86.5	83.5	75.0	458	435	420	3250	246.2	170	145	250	46.69	1765
315	420	988	355CB	95.8	95.8	95.5	87.0	85.0	78.0	574	546	526	3700	310.2	170	145	250	55.29	2800

Note:

1. The above are typical values based on test according to IEC 60034-2-1 :2007.(DY)
2. Tolerance according to IEC 60034-1.
3. Breakdown & Locked rotor torques are show as average expected voltages
4. Efficiency, power factor, speed and torque are the same for other voltages.
Current values vary inversely with voltage
5. Output in () is for Optional Frame size upon request
6. Frame size 315C, 315D, & 355C: only suitable for IM B3 and IM B35
7. Noise according to IEC 60034-9.
8. Data subject to change without prior notice.



IE 3 PERFORMANCE DATA (8 POLE)

Motor Type: AESV3S / AESU3S / AESV3S-LA

OUTPUT		FULL LOAD rpm	FRAME No.	EFFICIENCY			POWER FACTOR			CURRENT				TORQUE				ROTOR GD ² kg-m ²	APPROX. WEIGHT kg
				FULL LOAD (%)	3/4 LOAD (%)	1/2 LOAD (%)	FULL LOAD (%)	3/4 LOAD (%)	1/2 LOAD (%)	FULL LOAD (A) VOLTAGE			LRC (A)	FULL LOAD kg-m	LOCKED ROTOR %FLT	PULL-UP %FLT	BREAK-DOWN %FLT		
kW	HP									380	400	415	400V						
0.18	0.25	705	80M	58.7	53.9	46.2	51.5	43.5	35.5	0.90	0.86	0.83	3.4	0.248	300	275	305	0.013	17.4
0.37	0.5	705	90S	69.3	66.6	62.3	59.0	48.5	39.0	1.37	1.31	1.26	4.8	0.511	195	175	235	0.017	21.2
0.55	0.75	705	90L	73.0	71.5	68.9	63.5	53.0	42.5	1.80	1.71	1.65	6.8	0.759	170	150	220	0.025	24.6
0.75	1	700	10 L	75.0	74.7	70.9	60.5	51.0	39.0	2.51	2.39	2.30	10	1.043	225	215	235	0.041	31.2
1.1	1.5	695	100L	77.7	78.8	76.8	66.0	57.0	44.0	3.26	3.10	2.98	13	1.540	200	190	210	0.059	37.9
1.5	2	700	112M	79.7	80.2	79.1	69.5	61.0	48.0	4.11	3.91	3.77	18	2.085	165	140	205	0.090	49.7
2.2	3	705	132S	81.9	82.2	79.8	69.0	60.0	46.5	5.91	5.62	5.42	31	3.036	230	205	265	0.138	62.0
3	4	715	132M	83.5	83.2	80.1	63.0	53.5	40.5	8.66	8.23	7.93	47	4.083	280	250	325	0.180	68.0
3.7	5	72	160M	84.4	83.7	80.7	69.0	60.5	47.0	9.65	9.17	8.84	59	4.966	250	247	365	0.343	106
4	5.5	720	160M	84.8	84.7	82.5	70.5	62.0	48.5	10.2	9.66	9.31	57	5.406	190	170	250	0.343	106
5.5	7.5	720	160M	86.2	85.2	83.3	71.5	63.0	50.0	13.6	12.9	12.4	78	7.433	200	185	275	0.503	125
7.5	10	720	160L	87.3	87.3	85.8	71.0	64.5	51.0	18.4	17.5	16.8	104	10.14	225	215	295	0.670	144
11	15	720	180L	88.6	88.6	88.1	78.0	73.0	62.0	24.2	23.0	22.1	130	14.87	170	150	210	1.273	187
15	20	730	200L	89.6	88.9	87.5	78.0	72.0	60.0	32.6	31.0	29.9	187	19.99	195	170	230	2.082	266
18.5	25	735	225SC	90.1	90.6	89.6	72.0	65.5	58.0	43.3	41.2	39.7	220	24.49	210	185	235	2.675	300
22	30	735	225MC	90.6	90.6	90.6	74.5	69.0	63.0	49.5	47.0	45.3	240	29.12	210	170	215	3.023	340
30	40	735	250MC	91.3	91.3	91.3	74.5	68.0	58.0	67.0	63.7	61.4	350	39.71	210	170	245	4.565	419
37	50	735	280SB	91.8	92.3	91.3	78.0	73.4	63.2	78.5	74.6	71.9	429	48.98	135	130	230	6.277	526
45	60	735	280MB	92.2	92.7	92.2	76.0	71.5	61.0	97.6	92.7	89.3	542	59.57	140	130	220	7.726	597
55	75	735	315SB	92.5	92.6	92.0	82.0	77.5	68.5	110	105	101	677	72.81	130	115	260	9.983	711
75	100	738	315MB	93.1	93.3	92.9	81.0	78.5	70.0	151	144	138	775	98.88	135	120	260	22.33	850
90	125	738	315LB	93.4	93.6	93.1	80.0	75.5	65.5	183	174	168	1008	118.7	160	145	225	24.01	1026
110	150	738	315LB	93.7	94.0	93.7	80.0	78.5	70.0	223	212	204	1181	145.0	150	135	210	30.15	1056
(132)	(175)	740	315CB	94.0	93.9	93.0	80.0	75.5	65.0	267	253	244	1679	173.6	105	90	260	36.29	1650
132	175	740	355MB	94.0	93.9	93.0	80.0	75.5	65.0	267	253	244	1679	173.6	105	90	260	36.29	1455
(160)	(215)	740	315CB	94.3	94.2	93.5	80.0	74.5	63.5	322	306	295	2073	210.4	110	95	265	42.34	1760
160	215	740	355MB	94.3	94.2	93.5	80.0	74.5	63.5	322	306	295	2073	210.4	110	95	265	42.34	1565
(200)	(270)	740	315DB	94.6	94.6	94.0	80.0	75.5	65.0	402	381	368	2571	263.0	110	95	260	52.93	1870
200	270	740	355LB	94.6	94.6	94.0	80.0	75.5	65.0	402	381	368	2571	263.0	110	95	260	52.93	1675
(220)	(300)	740	315DB	94.6	94.6	94.1	80.5	76.0	66.0	439	417	402	2798	289.3	110	95	260	58.22	1980
220	300	740	355LB	94.6	94.6	94.1	80.5	76.0	66.0	439	417	402	2798	289.3	110	95	260	58.22	1785
250	335	740	355CB	94.6	94.8	94.6	82.0	79.0	69.0	490	465	448	3419	328.7	130	115	260	74.99	2580

Note:

1. The above are typical values based on test according to IEC 60034-2-1 :2007.(DY)
2. Tolerance according to IEC 60034-1.
3. Breakdown & Locked rotor torques are show as average expected voltages
4. Efficiency, power factor, speed and torque are the same for other voltages.
Current values vary inversely with voltage
5. Output in () is for Optional Frame size upon request
6. Frame size 315C, 315D, & 355C: only suitable for IM B3 and IM B35
7. Noise according to IEC 60034-9.
8. Data subject to change without prior notice.

B3 OUTLINE DIMENSION

Foot Mounted(B3)
 Motor Type: AESV1S / AESV2S / AESV3S
 Frame Size: 80M to 225M

B3

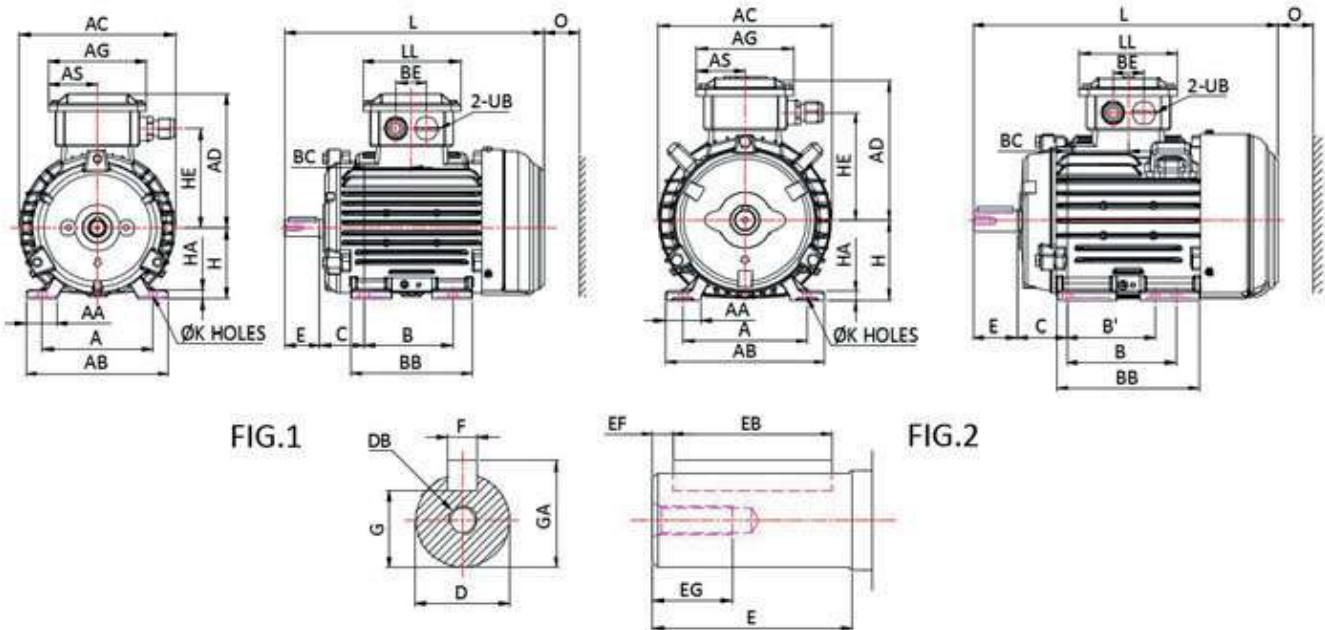

OUTPUT (kW)				FRAME SIZE	FIG. NO	A	AA	AB	AC	AD	AG	AS	B	B'	BA	BA'	BB	BC	BE	C
2P	4P	6P	8P																	
0.75 1.1	0.55 0.75	0.55	0.18	80M	1	12	34.5	161	177	152	109	54.5	100	---	---	---	137	53.5	35	50
1.5	1.1	0.75	0.37	90S	2	140	40	180	197	162	109	54.5	100	---	---	---	161	69.5	35	56
2.2	1.5	1.1	0.55	90L		140	40	180	197	162	109	54.5	125	---	---	---	171	74.5	35	56
3	2.2 3	1.5	0.75 1.1	100L		160	40	200	219	178.5	125	62.5	140	---	---	---	181	72.5	40	63
3.7 4	3.7 4	2.2	1.5	112M		190	45	235	235	191	125	62.5	140	---	---	---	186	75	40	70
5.5 7.5	5.5	3	2.2	132S		216	57	263	273	208.5	125	62.5	140	---	---	---	184	65	40	89
---	7.5	3.7 4 5.5	3	132M		216	57	263	273	208.5	125	62.5	178	140	---	---	222	84	40	89
11 15	11	7.5	3.7 4 5.5	160M	3	254	60	300	317	237	166	83	210	---	57	57	250	105	60	108
18.5	15	11	7.5	160L		254	60	300	317	237	166	83	254	210	97	97	294	127	60	108
22	18.5	---	---	180M		279	65	330	354	263.5	166	83	241	---	65	65	292	120.5	60	121
---	22	15	11	180L		279	65	330	354	263.5	166	83	279	241	115	115	330	139.5	60	121
30 37	30	18.5 22	15	200L	4	318	70	378	398	329	231	110.5	305	---	82	82	353	152.5	106	133
---	37	---	18.5	225SC		356	75	431	449	355	231	110.5	286	---	98.5	98.5	371	143	106	149
45	---	---	---	225MA		356	75	431	449	355	231	110.5	311	286	110	110	396	155.5	106	149
---	45	30	22	225MC		356	75	431	449	355	231	110.5	311	286	110	110	396	155.5	106	149

Note:

1. All dimensions are in mm.
2. Pre-packed shielded ball bearing for frame size 80M to 225M
3. Lifting Lugs provided for frame 90S to 355C
4. Data are subject to change without prior notice

B3 OUTLINE DIMENSION

B3

Foot Mounted(B3)
Motor Type: AESV1S / AESV2S / AESV3S
Frame Size: 80M to 225M

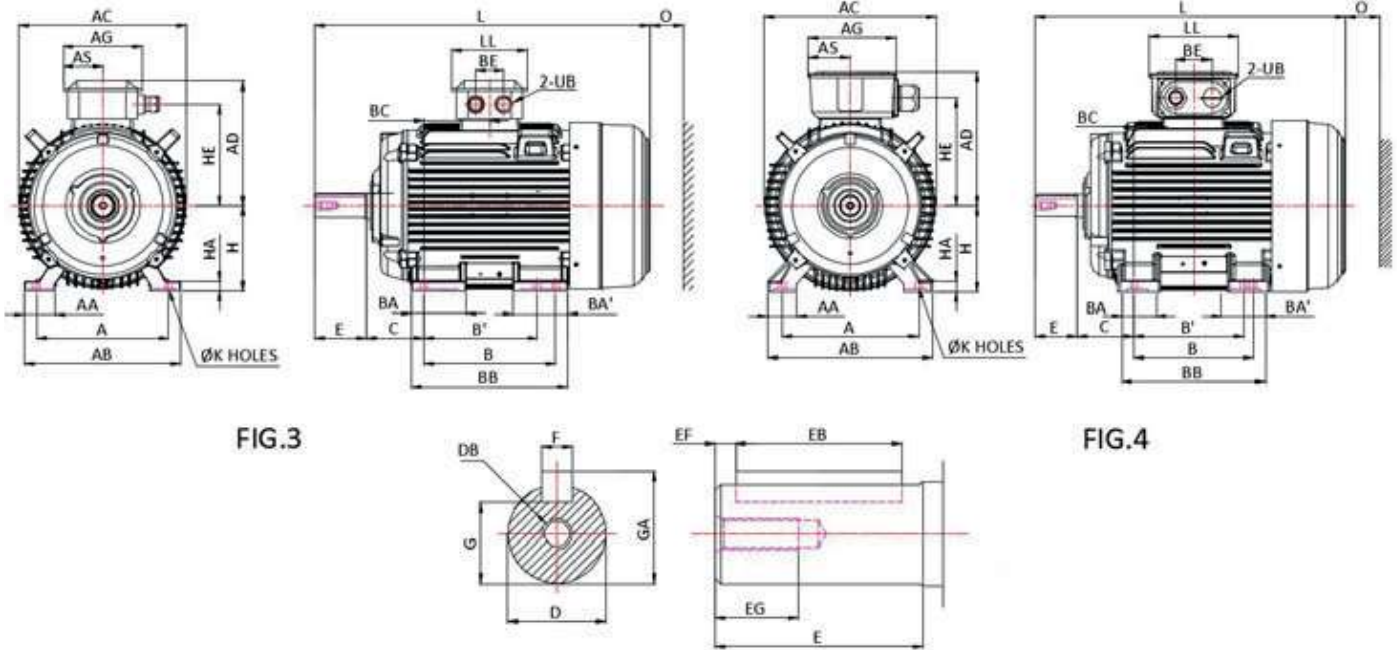

FIG.3

FIG.4

FRAME SIZE	H	HA	E	K	L	LL	O	UB	SHAFT EXTENSION								BEARING		
									D	E	EB	EF	EG	F	G	GA	DB	DRIVE END	OPPOSITE DRIVE END
80M	80	10	115	10	292	109	40	M20x1.5	19	40	32	4	16	6	15.5	21.5	M6	6204ZZC3	6203ZZC3
90S	90	10	125	10	344	109	40	M20x1.5	24	50	40	5	19	8	20	27	M8	6205ZZC3	6204ZZC3
90L	90	10	125	10	354	109	40	M20x1.5	24	50	40	5	19	8	20	27	M8	6206ZZC3	6205ZZC3
100L	100	12	146	12	391	125	50	M25x1.5	28	60	50	5	22		24	31	M10	6206ZZC3	6205ZZC3
112M	112	13	153.5	12	412.5	125	50	M25x1.5	28	60	50	5	22		24	31	M10	6306ZZC3	6305ZZC3
132S	132	16	171	12	456	125	50	M25x1.5	38	80	70	5	28	10	33	41	M12	6308ZZC3	6306ZZC3
132M	132	16	171	12	494	125	50	M25x1.5	38	80	70	5	28	10	33	41	M12		
160M	160	18	195	14.5	608	158	60	M32x1.5	42	110	10		36	12	37	45	M16	6309ZZC3	6307ZZC3
160L	160	18	195	14.5	652	158	60	M32x1.5	42	110	100	5	36	12	37	45	M16	6311ZZC3	6310ZZC3
180M	180	20	221	14.5	672	158	70	M32x1.5	48	110	100	5	36	14	42.5	51.5	M16		
180L	180	20	221	14.5	710	158	70	M32x1.5	48	110	100	5	36	14	42.5	51.5	M16	6312ZZC3	6212ZZC3
200L	200	24	259	18.5	770	231	80	M50x1.5	55	11			42	16	49	59	M20	6313ZZC3	6213ZZC3
225SC	225	28	285	18.5	816	231	90	M50x1.5	60	140	125	7.5	42	18	53	64	M20	6312ZZC3	6212ZZC3
225MA	225	28	285	18.5	811	231	90	M50x1.5	55	110	100	5	42	16	49	59	M20	6313ZZC3	6213ZZC3
225MC	225	28	285	18.5	841	231	90	M50x1.5	60	140	125	7.5	42	18	53	64	M20	6313ZZC3	6213ZZC3

Note:

1. All dimensions are in mm.
2. Tolerance of shaft end diameter D: 1) $\varnothing 19\sim\varnothing 28:j6$, 2) $\varnothing 38\sim\varnothing 48:k6$, 3) $\varnothing 55\sim\varnothing 65:m6$
3. Tolerance of shaft center height H : +0, -0.5
4. Data are subject to change without prior notice

B3 OUTLINE DIMENSION

Foot Mounted(B3)
 Motor Type: AESV1S / AESV2S / AESV3S
 Frame Size: 250M to 355C

B3

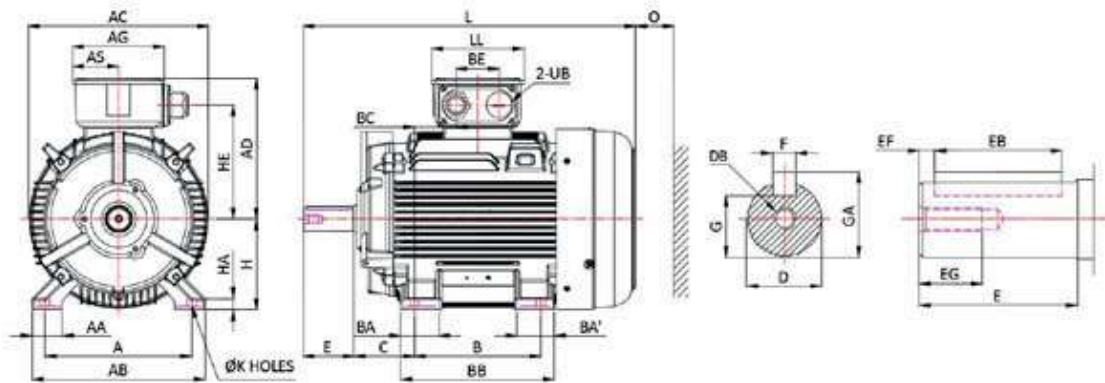

FIG.5

OUTPUT (kW)				FRAME SIZE	FIG. NO	A	AA	AB	AC	AD	AG	AS	B	B'	BA	BA'	BB	BC	BE	C
2P	4P	6P	8P																	
55	---	---	---	250MA	5	406	85	480	499	397	255	122.5	349	---	112.5	112.5	425	174.5	119	168
---	55	37	30	250MC		406	85	480	499	397	255	122.5	349	---	112.5	112.5	425	174.5	119	168
75	---	---	---	280SA	6	457	110	560	546	433	255	122.5	368	---	110	110	455	48	119	190
---	75	45	37	280SB		457	110	560	546	433	255	122.5	368	---	110	110	455	48	119	190
90	---	---	---	280MA		457	110	560	546	433	255	122.5	419	---	115	115	505	48	119	190
---	90	55	45	280MB		457	110	560	546	433	255	122.5	419	---	115	115	505	48	119	190
110	---	---	---	315SA		508	115	615	570	490	336	163	406	---	180	180	580	53	140	216
---	110	75	55	315SB		508	115	615	570	490	336	163	406	---	180	180	580	53	140	216
132 (160)	---	---	---	315MA		508	115	630	620	515	336	163	457	---	230	230	640	53	140	216
---	132 (160)	90 (110)	75	315MB		508	115	630	620	515	336	163	457	---	230	230	640	53	140	216
160 200	---	---	---	315LA		508	130	630	620	515	336	163	508	---	230	230	740	53	140	216
---	160 200	110 132 (160)	90 110	315LB		508	130	630	620	515	336	163	508	---	230	230	740	53	140	216
(220) (250)	---	---	---	315CA	508	150	650	682	590	412	189	710	---	335	335	870	68	180	216	
---	(220) (250)	(200) (220)	(132) (160)	315CB	508	150	650	682	590	412	189	710	---	335	335	870	68	180	216	
(315)	---	---	---	315DA	508	150	650	682	590	412	189	900	---	180	250	1060	68	180	216	
---	(315)	(250)	(200) (220)	315DB	508	150	650	682	590	412	189	900	---	180	250	1060	68	180	216	
220 250	---	---	---	355MA	610	150	750	682	585	412	189	---	560	310	310	910	48	180	254	
---	220 250	160 200 220	132 160	355MB	610	150	750	682	585	412	189	---	560	310	310	910	48	180	254	
315	---	---	---	355LA	610	150	750	682	585	412	189	630	---	310	310	910	48	180	254	
---	315	250	200 220	355LB	610	150	750	682	585	412	189	630	---	310	310	910	48	180	254	
375	---	---	---	355CA	610	150	750	810	645	412	189	900	---	390	390	1100	48	180	254	
---	375	315	250	355CB	610	150	750	810	645	412	189	900	---	390	390	1100	48	180	254	

Note:

1. All dimensions are in mm.
2. Open type ball bearing for frame size 250M to 355C
3. Lifting Lugs provided for frame 90S to 355C
4. Output in () is for optional frame size upon request
5. Data are subject to change without prior notice

B3

Foot Mounted(B3)
Motor Type: AESV1S / AESV2S / AESV3S
Frame Size: 250M to 355C

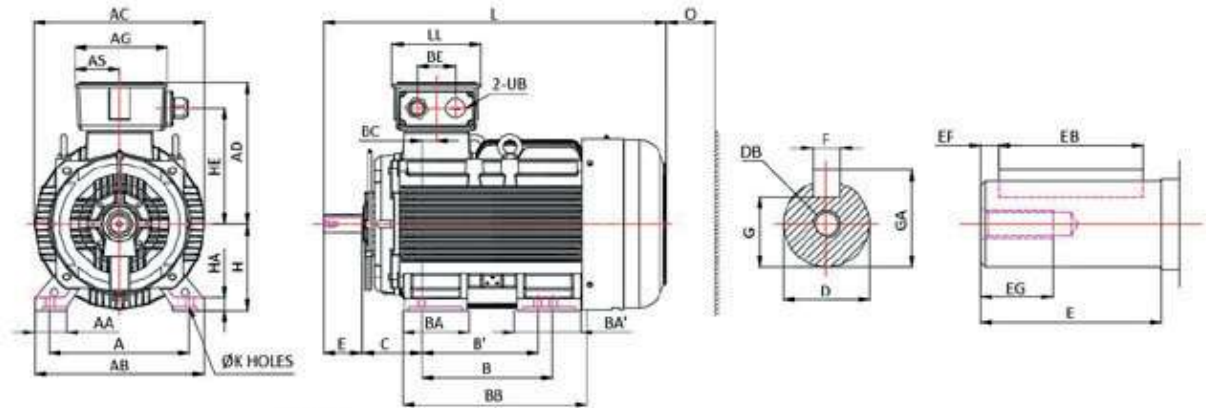

FIG.6

FRAME SIZE	H	HA	HE	K	L	LL	O	UB	SHAFT EXTENSION								BEARING		
									D	E	EB	EF	EG	F	G	GA	DB	DRIVE END	OPPOSITE DRIVE END
250MA	250	30	319	24	921	255	105	M63x1.5	60	140	125	7.5	42	18	53	64	M20	6313C3	6313C3
250MC	250	30	319	24	921	255	105	M63x1.5	65	140	125	7.5	42	18	58	69	M20	6315C3	6313C3
280SA	280	35	354.5	24	1037.5	255	140	M63X1.5	65	140	125	7.5	40	18	58	69	M20	6314C3	6314C3
280SB	280	35	354.5	24	1037.5	255	140	M63X1.5	75	140	125	7.5	40	20	67.5	79.5	M20	6318C3	6316C3
280MA	280	35	354.5	24	1087.5	255	140	M63X1.5	65	140	125	7.5	40	18	58	69	M20	6314C3	6314C3
280MB	280	35	354.5	24	1087.5	255	140	M63X1.5	75	140	125	7.5	40	20	67.5	79.5	M20	6318C3	6316C3
315SA	315	35	395	28	1162	322	180	M63X1.5	65	140	125	7.5	40	18	58	69	M20	6316C3	6314C3
315SB	315	35	395	28	1192	322	180	M63X1.5	80	170	160	5	40	22	71	85	M20	6320C3	6316C3
315MA	315	45	420	28	1243	322	180	M63X1.5	65	140	125	7.5	40	18	58	69	M20	6316C3	6314C3
315MB	315	45	420	28	1273	322	180	M63X1.5	80	170	160	5	40	22	71	85	M20	6320C3	6316C3
315LA	315	45	420	28	1346	322	180	M63X1.5	65	140	125	7.5	40	18	58	69	M20	6316C3	6314C3
315LB	315	45	420	28	1376	322	180	M63X1.5	80	170	160	5	40	22	71	85	M20	6320C3	6316C3
315CA	315	45	485	28	1484	372	200	M72X2	75	140	125	7.5	40	20	67.5	79.5	M20	6316C3	6316C3
315CB	315	45	485	28	1514	372	200	M72X2	95	170	160	5	48	25	86	100	M24	6322C3	6322C3
315DA	315	45	485	28	1674	372	200	M72X2	75	140	125	7.5	40	20	67.5	79.5	M20	6316C3	6316C3
315DB	315	45	485	28	1704	372	200	M72X2	95	170	160	5	48	25	86	100	M24	6322C3	6322C3
355MA	355	45	480	28	1717	372	230	M72X2	80	170	140	5	40	22	71	85	M20	6318C3	6318C3
355MB	355	45	480	28	1757	372	230	M72X2	100	210	180		48	28	90	106	M24	6322C3	6322C3
355LA	355	45	480	28	1717	372	230	M72X2	80	170	140	5	40	22	71	85	M20	6318C3	6318C3
355LB	355	45	480	28	1757	372	230	M72X2	100	210	18		48	28	90	106	M24	6322C3	6322C3
355CA	355	45	540	28	1795	372	230	M72X2	80	170	140	5	40	22	71	85	M20	6318C3	6318C3
355CB	355	45	540	28	1835	372	230	M72X2	100	210	180		48	28	90	106	M24	6322C3	6322C3

Note:

1. All dimensions are in mm.
2. Tolerance of shaft end diameter D: 1) Ø55~Ø100:m6
3. Tolerance of shaft center height H : 1) 80~250: +0, -0.5, 2) 280~355: +0, -1
4. Data are subject to change without prior notice

V1 OUTLINE DIMENSION

Flange Mounted(V1)
 Motor Type: AESU1S / AESU2S / AESU3S
 Frame Size: 80M to 225M

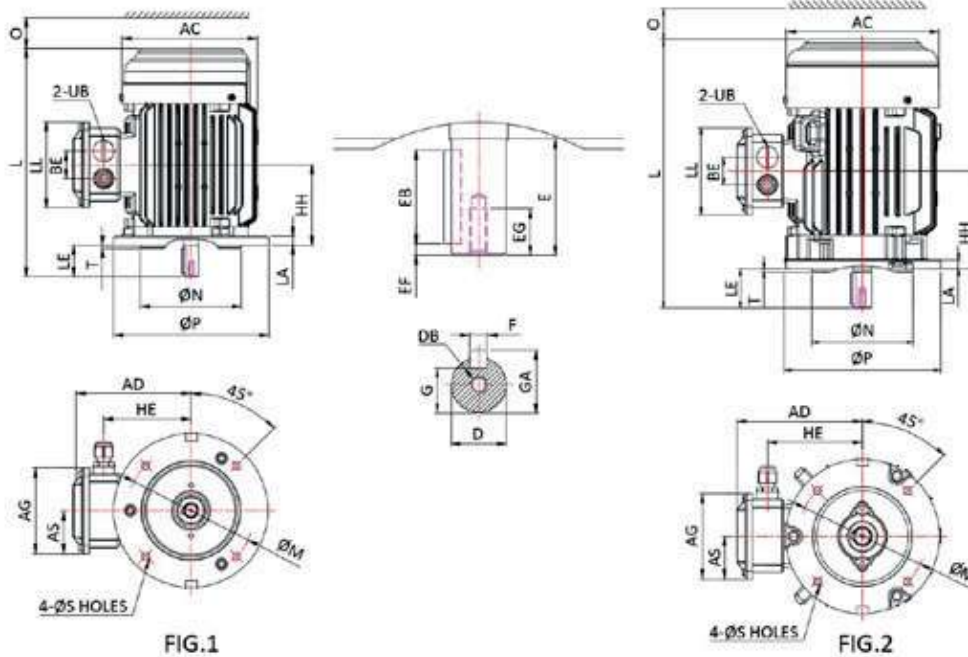

OUTPUT (kW)				FRAME SIZE	FIG. NO	FLANGE DIMENSION							AC	AD	AG	AS	BE	HE
2P	4P	6P	8P			LA	LE	M	N	P	S	T						
0.75 1.1	0.55 0.75	0.55	0.18	80M	1	12	40	165	130	200	12	3.5	177	152	109	54.5	35	115
1.5	1.1	0.75	0.37	90S	2	12	50	165	130	200	12	3.5	197	162	109	54.5	35	125
2.2	1.5	1.1	0.55	90L		12	50	165	130	200	12	3.5	197	162	109	54.5	35	125
3	2.2 3	1.5	0.75 1.1	100L		16	60	215	180	250	14.5	4	219	178.5	125	62.5	40	146
3.7 4	3.7 4	2.2	1.5	112M		15	60	215	180	250	14.5	4	235	191	125	62.5	40	153.5
5.5 7.5	5.5	3	2.2	132S		16	80	265	230	300	14.5	4	273	208.5	125	62.5	40	171
---	7.5	3.7 4 5.5	3	132M		16	80	265	230	300	14.5	4	273	208.5	125	62.5	40	171
11 15	11	7.5	3.7 4 5.5	160M	3	15	110	300	250	350	18.5	5	317	237	166	83	60	195
18.5	15	11	7.5	160L		15	110	300	250	350	18.5	5	317	237	166	83	60	195
22	18.5	---	---	180M		15	110	300	250	350	18.5	5	354	263.5	166	83	60	221
---	22	15	11	180L		15	110	300	250	350	18.5	5	354	263.5	166	83	60	221
30 37	30	18.5 22	15	200L	4	17	110	350	300	400	18.5	5	398	329	231	110.5	106	259
---	37	---	18.5	225SC		20	140	400	350	450	18.5		450	355	231	110.5	106	285
45	---	---	---	225MA		20	110	400	350	450	18.5	5	450	355	231	110.5	106	285
---	45	30	22	225MC		20	140	400	350	450	18.5	5	450	355	231	110.5	106	285

Note:

1. All dimensions are in mm.
2. Tolerance of N: Ø130-Ø450: j6
3. Pre-packed shielded ball bearing for frame size 80M to 225M
4. Lifting Lugs provided for frame 90S to 355L
5. Data are subject to change without prior notice

V1 OUTLINE DIMENSION

V1

Flange Mounted(V1)
Motor Type: AESU1S / AESU2S / AESU3S
Frame Size: 80M to 225M

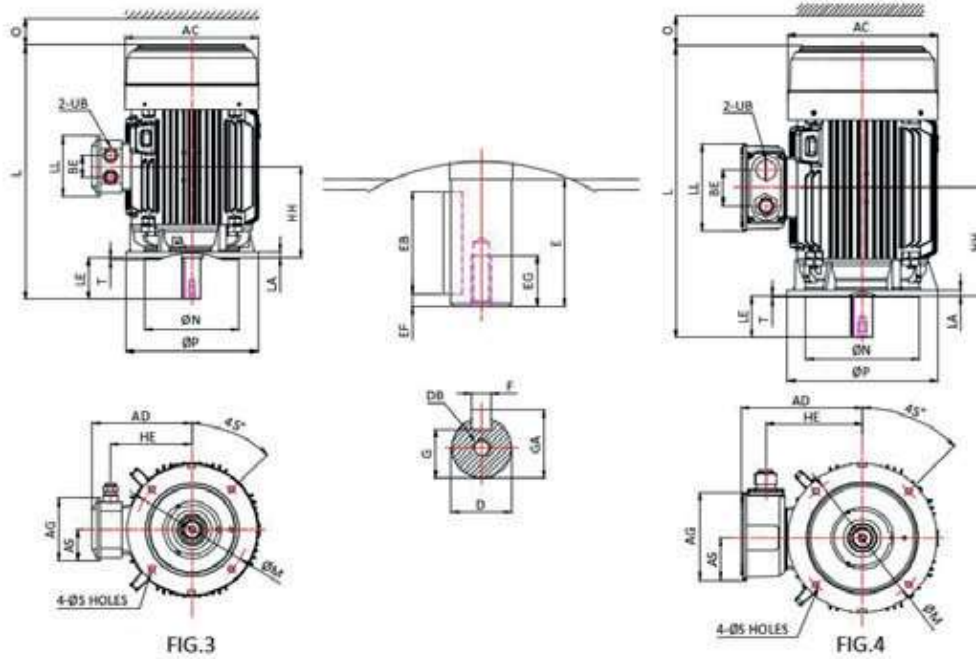

FRAME SIZE	HH	L	LL	O	UB	SHAFT EXTENSION										BEARING	
						D	E	EB	EF	EG	F	G	GA	DB	DRIVE END	OPPOSITE DRIVE END	
80M	103.5	292	109	40	M20X1.5	19	40	32	4	16	6	15.5	21.5	M6	6204ZZC3	6203ZZC3	
90S	130.5	344	109	40	M20X1.5	24	50	40	5	19	8	20	2	M8	6205ZZC3	6204ZZC3	
90L	130.5	354	109	40	M20X1.5	24	50	40	5	19	8	20	27	M8			
100L	135.5	391	125	50	M25X1.5	28	60	50	5	22		24	31	M10	6206ZZC3	6205ZZC3	
112M	145	412.5	125	50	M25X1.5	28	60	50	5	22		24	31	M10	6306ZZC3	6305ZZC3	
132S	154	456	125	50	M25X1.5	38	80	70	5	28	10	33	41	M12	6308ZZC3	6306ZZC3	
132M	173	494	125	50	M25X1.5	38	80	70	5	28	10	33	41	M12			
160M	213	608	158	60	M32x 1.5	42	110	10		36	12	37	45	M16	6309ZZC3	6307ZZC3	
160L	235	652	158	60	M32x 1.5	42	110	10		36	12	37	45	M16			
180M	241.5	672	158	70	M32x 1.5	48	110	100	5	36	14	42.5	51.5	M16	6311ZZC3	6310ZZC3	
180L	260.5	710	158	70	M32x 1.5	48	110	10		36	14	42.5	51.5	M16			
200L	285.5	770	231	80	M50x 1.5	55	110			42	16	49	59	M20	6312ZZC3	6212ZZC3	
225SC	292	816	231	90	M50 x 1.5	60	140	125	7.5	42	18	53	64	M20	6313ZZC3	6213ZZC3	
225MA	304.5	811	231	90	M50 x 1.5	55	110	1		42	16	49	59	M20	6312ZZC3	6212ZZC3	
225MC	304.5	841	231	90	M50 x 1.5	60	140	125	7.5	42	18	53	64	M20	6313ZZC3	6213ZZC3	

Note:

1. All dimensions are in mm.
2. Tolerance of shaft end diameter D: 1) $\varnothing 19\sim\varnothing 28$: j6, 2) $\varnothing 38\sim\varnothing 48$: k6, 3) $\varnothing 55\sim\varnothing 65$: m6,
3. Data are subject to change without prior notice

V1 OUTLINE DIMENSION

Flange Mounted(V1)
 Motor Type: AESU1S / AESU2S / AESU3S
 Frame Size: 250M to 355L

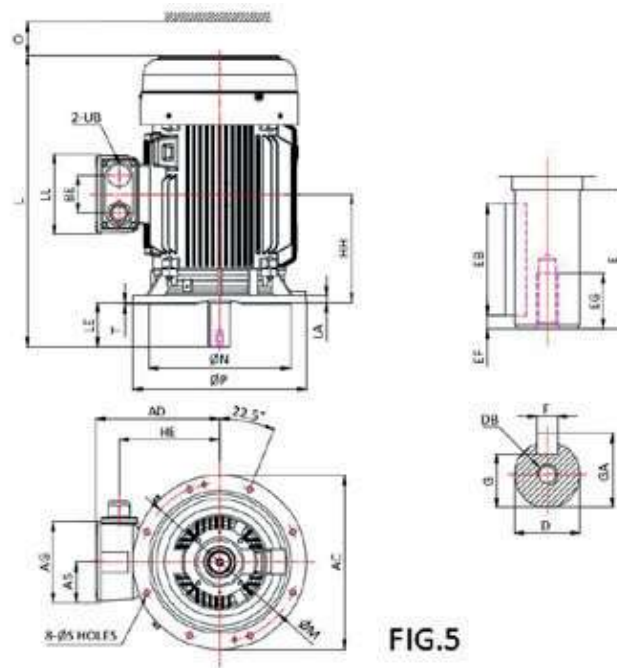

FIG.5

OUTPUT (kW)				FRAME SIZE	FIG. NO	FLANGE DIMENSION							AC	AD	AG	AS	BE	HE
2P	4P	6P	8P			LA	LE	M	N	P	S	T						
55	---	---	---	250MA	5	22	140	500	450	550	18.5	5	550	397	255	122.5	119	319
---	55	37	30	250MC		22	140	500	450	550	18.5	5	550	397	255	122.5	119	319
75	---	---	---	280SA	6	22	140	500	450	550	18.5	5	71	433	255	122.5	119	354.5
---	75	45	37	280SB		22	140	500	450	550	18.5	5	71	433	255	122.5	119	354.5
90	---	---	---	280MA		22	140	500	450	550	18.5	5	71	433	255	122.5	119	354.5
---	90	55	45	280MB		22	140	500	450	550	18.5	5	710	433	255	122.5	119	354.5
110	---	---	---	315SA		25	140	600	550	660	24	6	756	490	336	163	140	395
---	110	75	55	315SB		25	170	600	550	660	24	6	756	490	336	163	140	395
132 (160)	---	---	---	315MA		25	140	600	550	660	24	6	810	515	336	163	140	420
---	132 (160)	90 (110)	75	315MB		25	170	600	550	660	24	6	810	515	336	163	140	420
160 200	---	---	---	315LA		25	140	600	550	660	24	6	810	515	336	163	140	420
---	160 200	110 132 (160)	90 110	315LB		25	170	600	550	660	24	6	810	515	336	163	140	420
220 250	---	---	---	355MA	30	140	740	680	800	24	6	900	585	412	189	180	480	
---	220 250	160 200 220	132 160	355MB	30	170	740	680	800	24	6	900	585	412	189	180	480	
315	---	---	---	355LA	30	140	740	680	800	24	6	900	585	412	189	180	480	
---	315	250	200 220	355LB	30	170	740	680	800	24	6	900	585	412	189	180	480	

Note:

1. All dimensions are in mm.
2. Tolerance of N: $\varnothing 130\sim\varnothing 450$: j6, $\varnothing 550\sim\varnothing 680$: js6
3. Open type ball bearing for frame size 250M to 355L
4. Output in () is for optional frame size upon request
5. Lifting Lugs provided for frame 90S to 355L
6. Data are subject to change without prior notice

V1 OUTLINE DIMENSION

V1

Flange Mounted(V1)
Motor Type: AESU1S / AESU2S / AESU3S
Frame Size: 250M to 355L

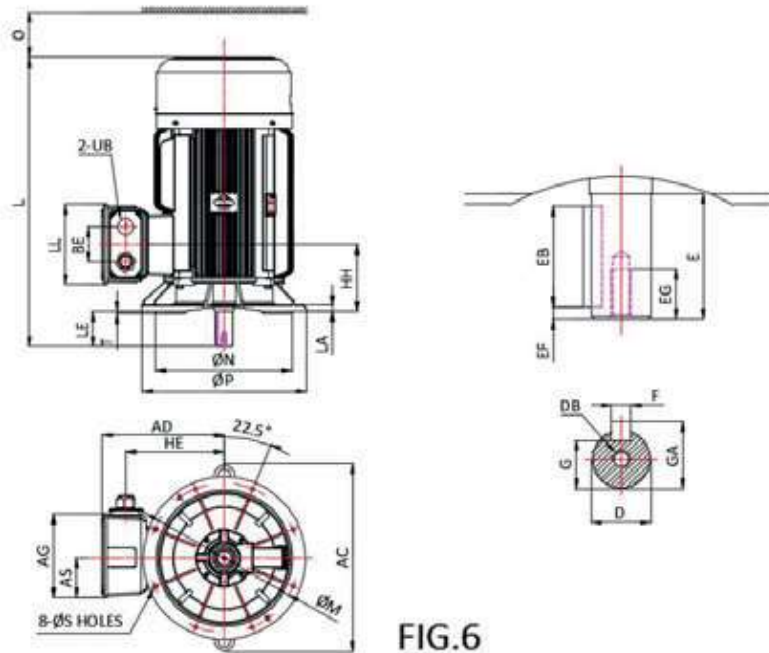

FIG.6

FRAME SIZE	HH	L	LL	O	UB	SHAFT EXTENSION										BEARING	
						D	E	EB	EF	EG	F	G	GA	DB	DRIVE END	OPPOSITE DRIVE END	
250MA	342.5	921	255	105	M63 x 1.5	60	140	125	7.5	42	18	53	64	M20	6313C3	6313C3	
250MC	342.5	921	255	105	M63 x 1.5	65	140	125	7.5	42	18	58	69	M20	6315C3	6313C3	
280SA	238	1037.5	255	140	M63X1.5	65	140	125	7.5	40	18	58	69	M20	6314C3	6314C3	
280SB	238	1037.5	255	140	M63X1.5	75	140	125	7.5	40	20	67.5	79.5	M20	6318C3	6316C3	
280MA	238	1087.5	255	140	M63X1.5	65	140	125	7.5	40	18	58	69	M20	6314C3	6314C3	
280MB	238	1087.5	255	140	M63X1.5	75	140	125	7.5	40	20	67.5	79.5	M20	6318C3	6316C3	
315SA	269	1162	322	180	M63X1.5	65	140	125	7.5	40	18	58	69	M20	6316C3	7314B	
315SB	269	1192	322	180	M63X1.5	80	170	160	5	40	22	71	85	M20	6320C3	7316B	
315MA	269	1243	322	180	M63X1.5	65	140	125	7.5	40	18	58	69	M20	6316C3	7314B	
315MB	269	1273	322	180	M63X1.5	80	170	160	5	40	22	71	85	M20	6320C3	7316B	
315LA	269	1346	322	180	M63X1.5	65	140	125	7.5	40	18	58	69	M20	6316C3	7314B	
315LB	269	1376	322	180	M63X1.5	80	170	160	5	40	22	71	85	M20	6320C3	7316B	
355MA	297	1717	372	230	M72X2	80	170	140	5	40	22	71	85	M20	6318C3	7318B	
355MB	297	1757	372	230	M72X2	100	210	180		48	28	90	106	M24	6322C3	7322B	
355LA	297	1717	372	230	M72X2	80	170	140	5	40	22	71	85	M20	6318C3	7318B	
355LB	297	1757	372	230	M72X2	100	210	180		48	28	90	106	M24	6322C3	7322B	

Note:

1. All dimensions are in mm.
2. Tolerance of shaft end diameter D: 1) Ø55~Ø100: m6,
3. Data are subject to change without prior notice

B35 OUTLINE DIMENSION

Foot & Flange Mounted(B35)
 Motor Type: AESV1S-LA / AESV2S-LA / AESV3S-LA
 Frame Size: 80M to 225M

B35

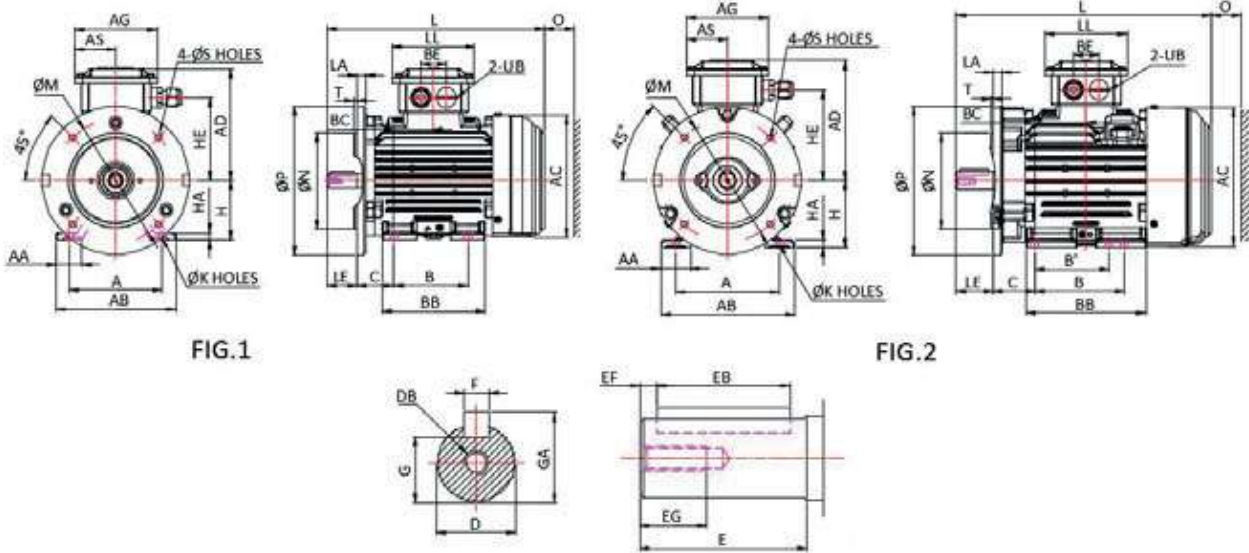

OUTPUT (kW)				FRAME SIZE	FIG. NO	FLANGE DIMENSION								A	AA	AB	AC	AD	AG	AS	B	B'	BA	BA'	BB
2P	4P	6P	8P			LA	LE	M	N	P	S	T													
0.75 1.1	0.55 0.75	0.55	0.18	80M	1	12	40	165	130	200	12	3.5	125	34.5	161	177	152	109	54.5	100	---	---	---	137	
1.5	1.1	0.75	0.37	90S	2	12	50	165	130	200	12	3.5	140	40	180	197	162	109	54.5	100	---	---	---	161	
2.2	1.5	1.1	0.55	90L		12	50	165	130	200	12	3.5	140	40	180	197	162	109	54.5	125	---	---	---	171	
3	2.2 3	1.5	0.75 1.1	100L		16	60	215	180	250	14.5	4	160	40	200	219	178.5	125	62.5	140	---	---	---	181	
3.7 4	3.7 4	2.2	1.5	112M		15	60	215	180	250	14.5	4	190	45	235	235	191	125	62.5	140	---	---	---	186	
5.5 7.5	5.5	3	2.2	132S		16	80	265	230	300	14.5	4	216	57	263	273	208.5	125	62.5	140	---	---	---	184	
---	7.5	3.7 4 5.5	3	132M		16	80	265	230	300	14.5	4	216	57	263	273	208.5	125	62.5	178	140	---	---	222	
11 15	11	7.5	3.7 4 5.5	160M	3	15	110	300	250	350	18.5	5	254	60	300	317	237	166	83	210	---	57	57	250	
18.5	15	11	7.5	160L		15	110	300	250	350	18.5		254	60	300	317	237	166	83	254	210	97	97	294	
22	18.5	---	---	180M		15	110	300	250	350	18.5	5	279	65	330	354	263.5	166	83	241	---	65	65	292	
---	22	15	11	180L		15	110	300	250	350	18.5	5	279	65	330	354	263.5	166	83	279	241	115	115	330	
30 37	30	18.5 22	15	200L	4	17	110	350	300	400	18.5	5	318	70	378	398	329	231	110.5	305	---	82	82	353	
---	37	---	18.5	225SC		20	140	400	350	450	18.5	5	356	75	431	449	355	231	110.5	286	---	98.5	98.5	371	
45	---	---	---	225MA		20	110	400	350	450	18.5	5	356	75	431	449	355	231	110.5	311	286	110	110	396	
---	45	30	22	225MC		20	140	400	350	450	18.5	5	356	75	431	449	355	231	110.5	311	286	110	110	396	

Note:

1. All dimensions are in mm.
2. Tolerance of N: Ø130~Ø450: j6
3. Pre-packed shielded ball bearing for frame size 80M to 225M
4. Lifting Lugs provided for frame 90S to 355C
5. Data are subject to change without prior notice

B35 OUTLINE DIMENSION

B35

Foot & Flange Mounted(B35)
 Motor Type: AESV1S-LA / AESV2S-LA / AESV3S-LA
 Frame Size: 80M to 225M

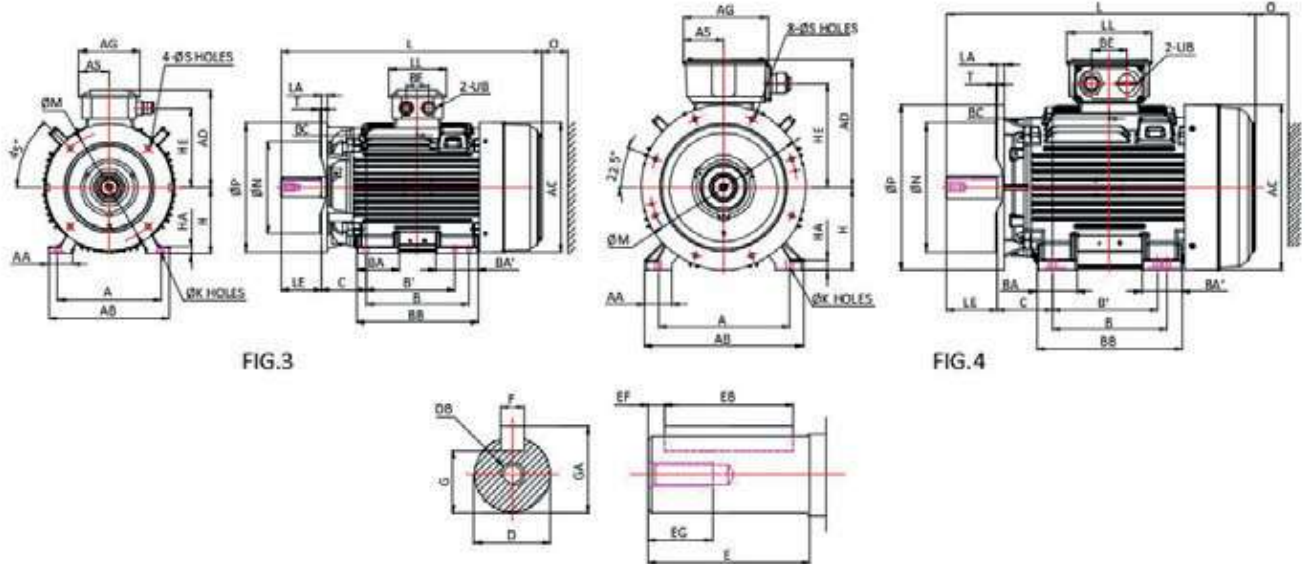

FRAME SIZE	BC	BE	C	H	HA	HE	K	L	LL	O	UB	SHAFT EXTENSION								BEARING		
												D	E	EB	EF	EG	F	G	GA	DB	DRIVE END	OPPOSITE DRIVE END
80M	53.5	35	50	80	10	115	10	292	109	40	M20x1.5	19	40	32	4	16	6	15.5	21.5	M6	6204ZZC3	6203ZZC3
90S	69.5	35	56	90	10	125	10	344	109	40	M20x1.5	24	50	40	5	19	8	20	27	M8	6205ZZC3	6204ZZC3
90L	74.5	35	56	90	10	125	10	354	109	40	M20x1.5	24	50	40	5	19	8	20	27	M8		
100L	72.5	40	63	100	12	146	12	391	125	50	M25x1.5	28	60	50	5	22		24	31	M10	6206ZZC3	6205ZZC3
112M	75	40	70	112	13	153.5	12	412.5	125	50	M25x1.5	28	60	50	5	22	8	24	31	M10	6306ZZC3	6305ZZC3
132S	65	40	89	132	16	171	12	456	125	50	M25x1.5	38	80	70	5	28	10	33	41	M12	6308ZZC3	6306ZZC3
132M	84	40	89	132	16	171	12	494	125	50	M25x1.5	38	80	70	5	28	10	33	41	M12		
160M	105	60	108	160	18	195	14.5	608	158	60	M32x1.5	42	110	100	5	36	12	37	45	M16	6309ZZC3	6307ZZC3
160L	127	60	108	160	18	195	14.5	652	158	60	M32x1.5	42	110	100	5	36	12	37	45	M16		
180M	120.5	60	121	180	20	221	14.5	672	158	70	M32x1.5	48	110	1		36	14	42.5	51.5	M16	6311ZZC3	6310ZZC3
180L	139.5	60	121	180	20	221	14.5	710	158	70	M32x1.5	48	110	100	5	36	14	42.5	51.5	M16		
200L	152.5	106	133	200	24	259	18.5	770	231	80	M50x1.5	55	110	10		42	16	49	59	M20	6312ZZC3	6212ZZC3
225SC	143	106	149	225	28	285	18.5	816	231	90	M50x1.5	60	140	125	7.5	42	18	53	64	M20	6313ZZC3	6213ZZC3
225MA	155.5	106	149	225	28	285	18.5	811	231	90	M50x1.5	55	110	10		42	16	49	59	M20	6312ZZC3	6212ZZC3
225MC	155.5	106	149	225	28	285	18.5	841	231	90	M50x1.5	60	140	125	7.5	42	18	53	64	M20	6313ZZC3	6213ZZC3

Note:

1. All dimensions are in mm.
2. Tolerance of shaft end diameter D: 1) $\varnothing 19\sim\varnothing 28$: j6, 2) $\varnothing 38\sim\varnothing 48$: k6, 3) $\varnothing 55\sim\varnothing 65$: m6
3. Tolerance of shaft center height H : +0, -0.5
4. Data are subject to change without prior notice

B35 OUTLINE DIMENSION

Foot & Flange Mounted(B35)
 Motor Type: AESV1S-LA / AESV2S-LA / AESV3S-LA
 Frame Size: 250M to 355C

B35

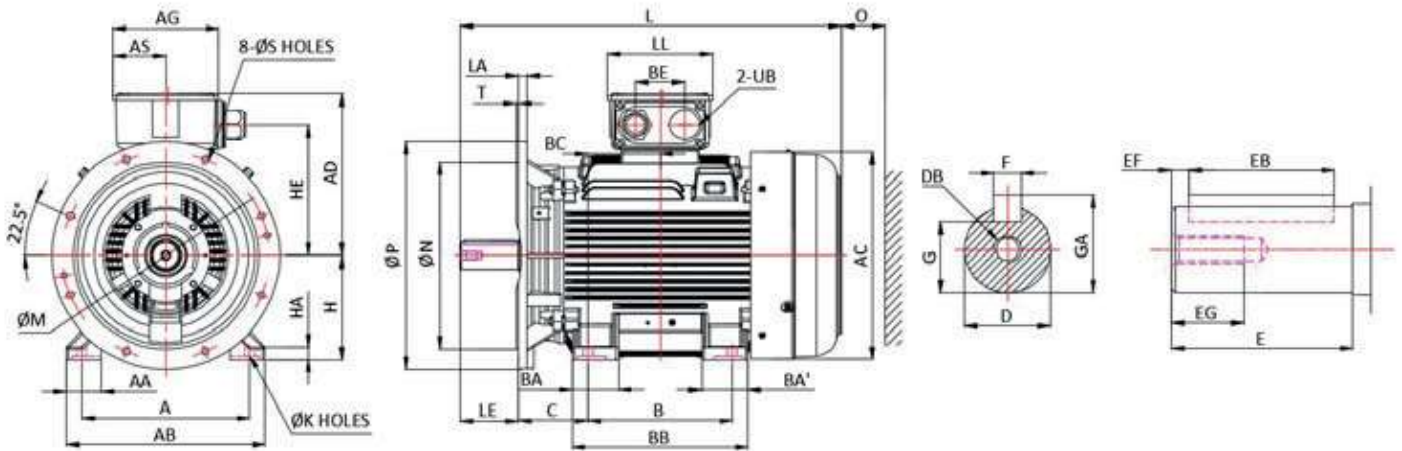

FIG.5

OUTPUT (kW)				FRAME SIZE	FIG. NO	FLANGE DIMENSION																		
2P	4P	6P	8P			LA	LE	M	N	P	S	T	A	AA	AB	AC	AD	AG	AS	B	B'	BA	BA'	BB
55	---	---	---	250MA	5	22	140	500	450	550	18.5	5	406	85	480	499	397	255	122.5	349	---	112.5	112.5	425
---	55	37	30	250MC		22	140	500	450	550	18.5	5	406	85	480	499	397	255	122.5	349	---	112.5	112.5	425
75	---	---	---	280SA		22	140	500	450	550	18.5	5	457	110	560	546	433	255	122.5	368	---	110	110	455
---	75	45	37	280SB		22	140	500	450	550	18.5	5	457	110	560	546	433	255	122.5	368	---	110	110	455
90	---	---	---	280MA		22	140	500	450	550	18.5	5	457	110	560	546	433	255	122.5	419	---	115	115	505
---	90	55	45	280MB		22	140	500	450	550	18.5	5	457	110	560	546	433	255	122.5	419	---	115	115	505
110	---	---	---	315SA		25	140	600	550	660	24	6	508	115	615	660	490	336	163	406	---	180	180	580
---	110	75	55	315SB		25	170	600	550	660	24	6	508	115	615	660	490	336	163	406	---	180	180	580
132 (160)	---	---	---	315MA		25	140	600	550	660	24	6	508	115	630	660	515	336	163	457	---	230	230	640
---	132 (160)	90 (110)	75	315MB		25	170	600	550	660	24	6	508	115	630	660	515	336	163	457	---	230	230	640
160 200	---	---	---	315LA	25	140	600	550	660	24	6	508	130	630	660	515	336	163	508	---	230	230	740	
---	160 200	110 132 (160)	90 110	315LB	25	170	600	550	660	24	6	508	130	630	660	515	336	163	508	---	230	230	740	
(220) (250)	---	---	---	315CA	6	30	140	600	550	660	24	6	508	150	650	682	590	412	189	710	---	335	335	870
---	(220) (250)	(200) (220)	(132) (160)	315CB		30	170	600	550	660	24	6	508	150	650	682	590	412	189	710	---	335	335	870
(315)	---	---	---	315DA		30	140	600	550	660	24	6	508	150	650	682	590	412	189	900	---	180	250	1060
---	(315)	(250)	(200) (220)	315DB		30	170	600	550	660	24	6	508	150	650	682	590	412	189	900	---	180	250	1060
220 250	---	---	---	355MA		30	140	740	680	800	24	6	610	150	750	800	585	412	189	---	560	310	310	910
---	220 250	160 200 220	132 160	355MB		30	170	740	680	800	24	6	610	150	750	800	585	412	189	---	560	310	310	910
315	---	---	---	355LA		30	140	740	680	800	24	6	610	150	750	800	585	412	189	630	---	310	310	910
---	315	250	200 220	355LB		30	170	740	680	800	24	6	610	150	750	800	585	412	189	630	---	310	310	910
375	---	---	---	355CA		30	140	740	680	800	24	6	610	150	750	810	645	412	189	900	---	390	390	1100
---	375	315	250	355CB		30	170	740	680	800	24	6	610	150	750	810	645	412	189	900	---	390	390	1100

Note:

1. All dimensions are in mm.
2. Tolerance of N: Ø130~Ø450: j6, Ø550~Ø680: js6
3. Open type ball bearing for frame size 250M to 355C
3. Lifting Lugs provided for frame 90S to 355C
4. Output in () is for optional frame size upon request
5. Data are subject to change without prior notice

B35 OUTLINE DIMENSION

B35

Foot & Flange Mounted(B35)
Motor Type: AESV1S-LA / AESV2S-LA / AESV3S-LA
Frame Size: 250M to 355C

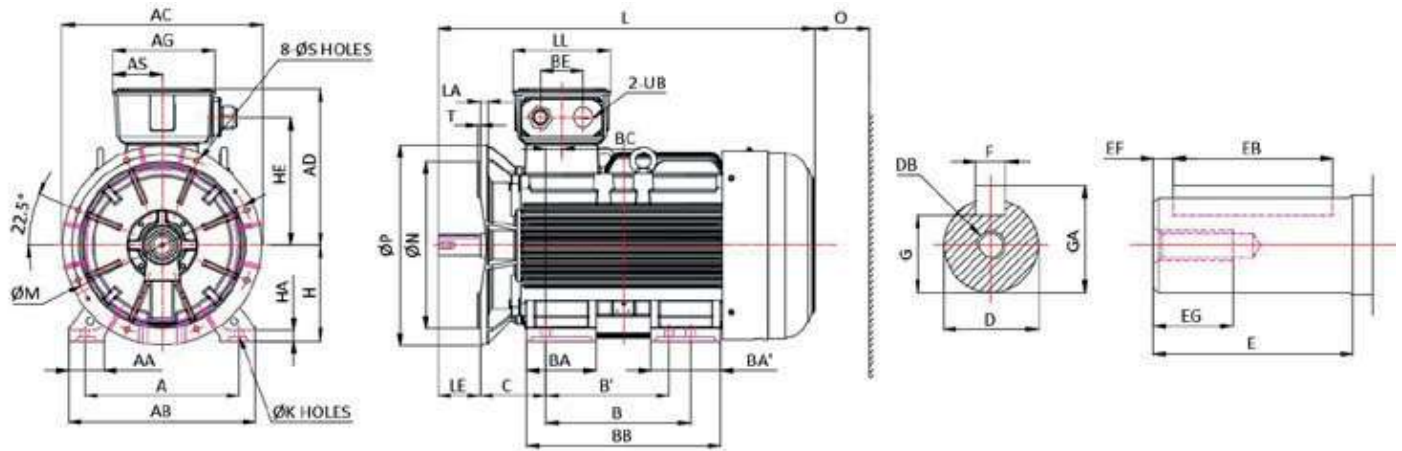

FIG.6

FRAME SIZE	BC	BE	C	H	HA	HE	K	L	LL	O	UB	SHAFT EXTENSION								BEARING		
												D	E	EB	EF	EG	F	G	GA	DB	DRIVE END	OPPOSITE DRIVE END
250MA	174.5	119	168	250	30	319	24	921	255	105	M63x1.5	60	140	125	7.5	42	18	53	64	M20	6313C3	6313C3
250MC	174.5	119	168	250	30	319	24	921	255	105	M63x1.5	65	140	125	7.5	42	18	58	69	M20	6315C3	6313C3
280SA	48	119	190	280	35	354.5	24	1037.5	255	140	M63X1.5	65	140	125	7.5	40	18	58	69	M20	6314C3	6314C3
280SB	48	119	190	280	35	354.5	24	1037.5	255	140	M63X1.5	75	140	125	7.5	40	20	67.5	79.5	M20	6318C3	6316C3
280MA	48	119	190	280	35	354.5	24	1087.5	255	140	M63X1.5	65	140	125	7.5	40	18	58	69	M20	6314C3	6314C3
280MB	48	119	190	280	35	354.5	24	1087.5	255	140	M63X1.5	75	140	125	7.5	40	20	67.5	79.5	M20	6318C3	6316C3
315SA	53	140	216	315	35	395	28	1162	322	180	M63X1.5	65	140	125	7.5	40	18	58	69	M20	6316C3	6314C3
315SB	53	140	216	315	35	395	28	1192	322	180	M63X1.5	80	170	160	5	40	22	71	85	M20	6320C3	6316C3
315MA	53	140	216	315	45	420	28	1243	322	180	M63X1.5	65	140	125	7.5	40	18	58	69	M20	6316C3	6314C3
315MB	53	140	216	315	45	420	28	1273	322	180	M63X1.5	80	170	160	5	40	22	71	85	M20	6320C3	6316C3
315LA	53	140	216	315	45	420	28	1346	322	180	M63X1.5	65	140	125	7.5	40	18	58	69	M20	6316C3	6314C3
315LB	53	140	216	315	45	420	28	1376	322	180	M63X1.5	80	170	160	5	40	22	71	85	M20	6320C3	6316C3
315CA	68	180	216	315	45	485	28	1484	372	200	M72X2	75	140	125	7.5	40	20	67.5	79.5	M20	6316C3	6316C3
315CB	68	180	216	315	45	485	28	1514	372	200	M72X2	95	170	160	5	48	25	86	100	M24	6322C3	6322C3
315DA	68	180	216	315	45	485	28	1674	372	200	M72X2	75	140	125	7.5	40	20	67.5	79.5	M20	6316C3	6316C3
315DB	68	180	216	315	45	485	28	1704	372	200	M72X2	95	170	160	5	48	25	86	100	M24	6322C3	6322C3
355MA	48	180	254	355	45	480	28	1717	372	230	M72X2	80	170	140	5	40	22	71	85	M20	6318C3	6318C3
355MB	48	180	254	355	45	480	28	1757	372	230	M72X2	100	210	180	5	48	28	90	106	M24	6322C3	6322C3
355LA	48	180	254	355	45	480	28	1717	372	230	M72X2	80	170	140	5	40	22	71	85	M20	6318C3	6318C3
355LB	48	180	254	355	45	480	28	1757	372	230	M72X2	100	210	180	5	48	28	90	106	M24	6322C3	6322C3
355CA	48	180	254	355	45	540	28	1795	372	230	M72X2	80	170	140	5	40	22	71	85	M20	6318C3	6318C3
355CB	48	180	254	355	45	540	28	1835	372	230	M72X2	100	210	180	5	48	28	90	106	M24	6322C3	6322C3







Note:

1. All dimensions are in mm.
2. Tolerance of shaft end diameter D: 1) $\phi 55\sim\phi 100$: m6
3. Tolerance of shaft center height H : 1) 80~250: +0, -0.5, 2) 280~355: +0, -1
4. Data are subject to change without prior notice

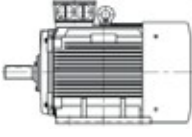
GENERAL ELECTRICAL FORMULAS

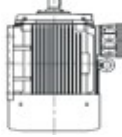
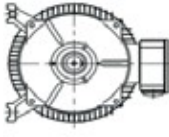
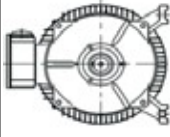
Name	Formula	Units	Definitions/ Notes
Output	1HP=746W=0.746kW		HP: horsepower
Current	$I = \frac{E}{R}$	I in A	E: volt R: Ohm
Input power	$P_{in} = E \cdot I \cdot \cos\phi \dots\dots\dots(1\Phi)$ $P_{in} = \sqrt{3} \cdot E \cdot I \cdot \cos\phi \dots\dots\dots(3\Phi)$	P_{in} in W	E: volt I: ampere
Output power	$P_{out} = E \cdot I \cdot \eta \cdot \cos\phi \dots\dots\dots(1\Phi)$ $P_{out} = \sqrt{3} \cdot E \cdot I \cdot \eta \cdot \cos\phi \dots\dots\dots(3\Phi)$	P_{out} in W	η : efficiency $\cos\phi$: power factor
Efficiency	$\eta = \frac{P_{out}}{P_{in}} \times 100\% = \frac{P_{in} - P_{loss}}{P_{in}} \times 100\%$	P_{loss} in W	
Power factor	$\cos\phi = \frac{P_{in}}{\sqrt{3} \cdot E \cdot I} \times 100\% \dots\dots\dots(3\Phi)$		
Synchronous speed	$N_s = \frac{120f}{P}$	N_s in min^{-1}	f: frequency of the power supply P: poles
Slip	$S = \frac{N_s - N}{N_s} \times 100\%$		N: motor speed
Torque	$T = \frac{974kW}{N}$	T in kgf-m	1 kgf-m=9.8 N-m
Power	$P = 1.027 NT$	P in W	
Starting time	$t_s = \frac{GD^2 N}{375(T_M - T_L)}$	t_s in sec GD^2 in kgm^2	GD^2 : inertia of system T_M : torque of motor
Braking time	$t_b = \frac{GD^2 N}{375(T_M + T_L)}$	t_b in sec	T_L : torque of load
Reactive power absorbed by the motor	$Q = \sqrt{3} \cdot E \cdot I \cdot \sin\phi \dots\dots\dots(3\Phi)$	Q in VAR	
Sound power level	$L_w = 10 \log\left(\frac{P}{P_o}\right)$ ($P_o = 10^{-12} W$)	L_w in dB	
Sound pressure level	$L_p = 20 \log\left(\frac{P}{P_o}\right)$ ($P_o = 2 \times 10^{-5} P_a$)	L_p in dB	$P_a=1 \text{ N/m}^2$

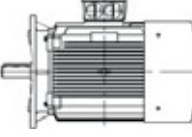
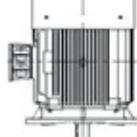
INTERNATIONAL MOUNTING CODE (IM)

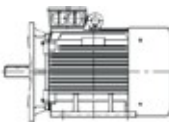
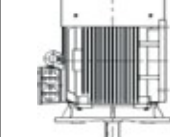
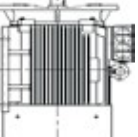
Foot-Mounted					
					
IM B3 (IM 1001)	IM V5 (IM 1011)	IM V6 (IM 1031)	IM B6 (IM 1051)	IM B7 (IM 1061)	IM B8 (IM 1071)
Flange-Mounted			Foot & Flange Mounted		
					
IM B5 (IM 3001)	IM V1 (IM 3011)	IM V3 (IM 3031)	IM B35 (IM 2001)	IM V15 (IM 2011)	IM V36 (IM 2031)

ENQUIRY FORM

Customer Name : _____ Company : _____

Contact Number : _____

Motor Specification Required

Efficiency Class (IE) : IE 1 IE 2 IE 3

Output : _____ kW / HP

Voltage : _____ Volts Frequency : _____ Hz

Poles : 2 4 6 8 Others : _____

Location : Indoor Outdoor Application : _____

Mounting : _____ (eg. B3,V1,B35)

Ingress Protection : IP55 IP56 Others: _____

Insulation Class : Class F (155 °C) Class H (180 °C)

Ambient Temperature : _____ °C

Temperature Rise : Class B (80 °C) Class F (105 °C)

Starting Method : Direct-On-Line Star-Delta Inverter

Inverter : IEC 60034-17:2006 Torque : Constant / Variable
 IEC 60034-25 Speed Range : From: __ To: __ Hz

Drive Method : Direct Coupling Belt drive Others: __

Quantity : _____



TECO ELECTRIC & MACHINERY PTE LTD

47 Tuas Ave 9,
Singapore 639190

Tel: +65 6265 4622 (General)
Tel: +65 6263 9269 (Local Sales)
Tel: +65 6263 9278 (Export Sales)

Fax: +65 6268 8651 (General)
Fax: +65 6265 7354 (Local Sales)
Fax: +65 6265 7354 (Export Sales)

Website: www.teco.com.sg
Email: ds@teco.com.sg (Local Sales)
Email: es@teco.com.sg (Export Sales)

**TECO ELECTRIC & MACHINERY
(THAI) CO., LTD**

128/1 Soi Watsrivarenooi, Moo 7,
Bangna Trad Road, Km. 18,
Bangchalong, Bangplee,
Samuthprakarn 10540
Thailand

Contact Person: Mr Pisut Sae Chong
Tel: (662) 3371311 ~ 20
Fax: (662) 3371630 ~ 1
Email: sales@teco.co.th

**TECO ELECTRIC & MACHINERY SDN BHD
(MALAYSIA HQ)**

TYM Electric & Machinery Sdn Bhd

PLO 52 (No.26), Jalan Firma 2/1,
Kawasan Perindustrian Tebrau 1,
81100 Johor Bahru, Johor,
Malaysia

Contact Person: Mr Y.S.Liew
Tel: (60) 7-3548008
Fax: (60) 7-3546107, (60) 7-3545017
Email: sales@teco.com.my

**TECO (VIETNAM) ELECTRIC &
MACHINERY CO., LTD**

Long Thanh Industrial Zone
Long Thanh Distric, Dong Nai Province
Vietnam

Contact Person: Mr Hang Quang Dung
Tel: (84) 61-3514 108
Fax: (84) 61-3514 110
Email: sales@teco.com.vn

<https://maybomteco.vn/>
HP: 0352183679

**PT.TECO MULTIGUNA ELEKTRO
(INDONESIA)**

Jl Bandengan Utara No.83/1-2-3
Jakarta 14440

Indonesia
Contact Person: Mr Abraham Anggara
Tel: (62-21) 6622201
Fax: (62-21) 6697029
Email: marketing@teco.id

**TECO INDUSTRIAL SYSTEM PVT
LTD (INDIA)**

No. 351 F.I.E.
Patpar Ganj Industrial Area
Delhi 110092
India

Contact Person: Mr. Suvek Kumar
Tel: (91) 11 22158705
Mobile: (91) 9540033881
Email: suvek@teco.co.in